

UJA1023

LIN-I/O slave

Rev. 04 — 5 July 2006

Product data sheet

1. General description

The UJA1023 is a stand-alone Local Interconnect Network (LIN) I/O slave that replaces basic components commonly used in electronic control units for input and output handling. The UJA1023 contains a LIN 2.0 controller, an integrated LIN transceiver which is LIN 2.0 / SAE J2602 compliant and LIN 1.3 compatible, a 30 k Ω termination resistor necessary for LIN-slaves, and eight I/O ports which are configurable via the LIN bus.

An automatic bit rate synchronization circuit adapts to any (master) bit rate between 1 kbit/s and 20 kbit/s. For this, an oscillator is integrated.

The LIN protocol will be handled autonomously and both Node Address (NAD) and LIN frame Identifier (ID) programming will be done by a master request and an optional slave response message in combination with a daisy chain or plug coding function.

The eight bidirectional I/O pins are configurable via LIN bus messages and can have the following functions:

- Input:
 - Standard input pin
 - Local wake-up
 - Edge capturing on falling, rising or both edges
 - Analog input pin
 - Switch matrix (in combination with output pins)
- Output:
 - Standard output pin as high-side driver, low-side driver or push-pull driver
 - Cyclic sense mode for local wake-up
 - PWM mode, for example, for back light illumination
 - Switch matrix (in combination with input pins)

On entering a low-power mode it is possible to hold the last output state or to change over to a user programmable output state. In case of a failure (e.g. LIN bus short to ground) the output changes over to a user programmable limp home output state and the low-power Limp home mode will be entered.

Due to the advanced low-power behavior the power consumption of the UJA1023 in low-power mode is minimal.

PHILIPS

2. Features

- Automatic bit rate synchronization to any (master) bit rate between 1 kbit/s and 20 kbit/s
- Integrated LIN 2.0 / SAE J2602 transceiver (including 30 kΩ termination resistor)
- Eight bidirectional I/O pins
- 4 × 2, 4 × 3, or 4 × 4 switch matrix to support reading and supplying a maximum number of 16 switches
- Outputs configurable as high-side and/or low-side driver and as cyclic or PWM driver
- 8-bit ADC
- Advanced low-power behavior
- On-chip oscillator
- Node Address (NAD) configuration via daisy chain or plug coding
- Inputs supporting local wake-up and edge capturing
- Configurable Sleep mode
- Limp home configuration in case of error conditions
- Extremely low electromagnetic emission
- High immunity against electromagnetic interference
- Bus line protected in accordance with ISO 7637
- Extended ambient temperature range (−40 °C to +125 °C)

3. Quick reference data

Table 1. Quick reference data

Symbol	Parameter	Conditions	Min	Typ	Max	Unit
V _{BAT}	supply voltage on pin BAT	all operating modes	6.5	-	27	V
I _{BAT}	supply current on pin BAT	LH sleep, Sleep and Limp home mode; V _{BAT} = 8.1 V to 27 V	[1]	-	45	65 μA
V _{LIN}	voltage on pin LIN	DC value	−27	-	+40	V
T _{vj}	virtual junction temperature		[2]	−40	-	+150 °C
V _{esd}	electrostatic discharge voltage on pins LIN, BAT, C1, C2 and C3	human body model; C = 100 pF; R = 1.5 kΩ	−8	-	+8	kV

[1] All outputs turned off, LIN recessive, V_{th1} selected.

[2] Junction temperature in accordance with IEC60747-1. An alternative definition of T_{vj} = T_{amb} + P × R_{th(j-a)}, where R_{th(j-a)} is a fixed value to be used for calculating T_{vj}. The rating for T_{vj} limits the allowable combinations of power dissipation (P) and ambient temperature (T_{amb}).

4. Ordering information

Table 2. Ordering information

Type number	Package		Version
	Name	Description	
UJA1023T	SO16	plastic small outline package; 16 leads; body width 3.9 mm	SOT109-1

5. Block diagram

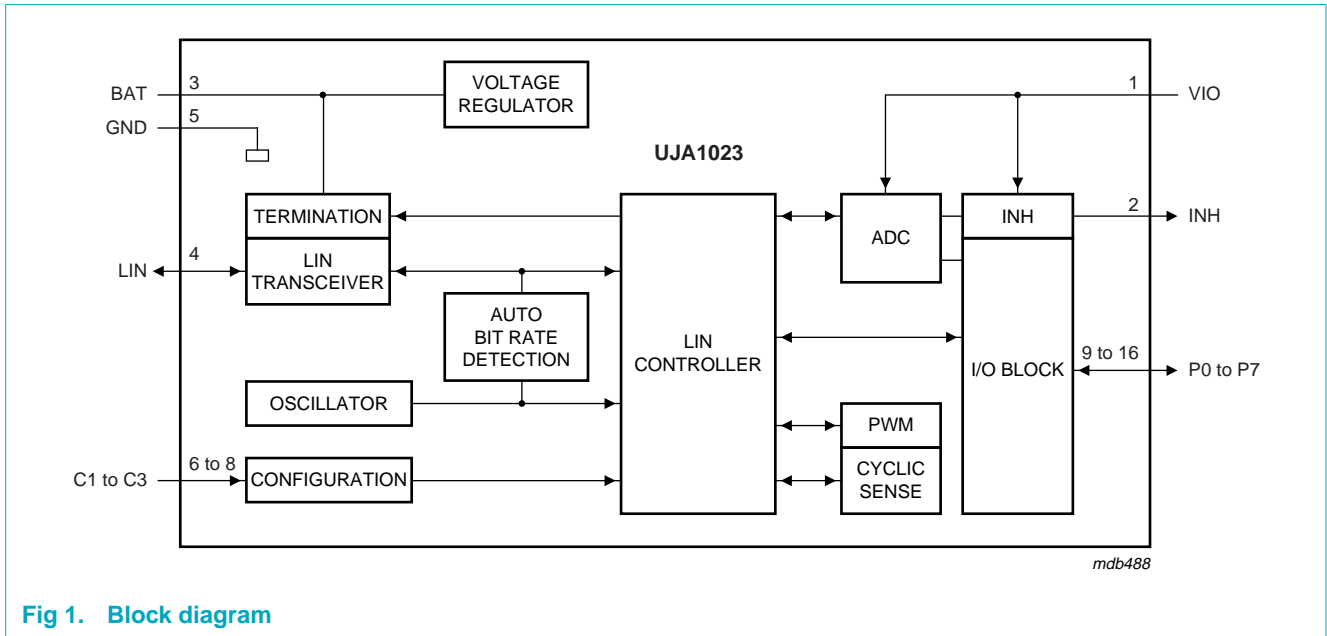

Fig 1. Block diagram

6. Pinning information

6.1 Pinning

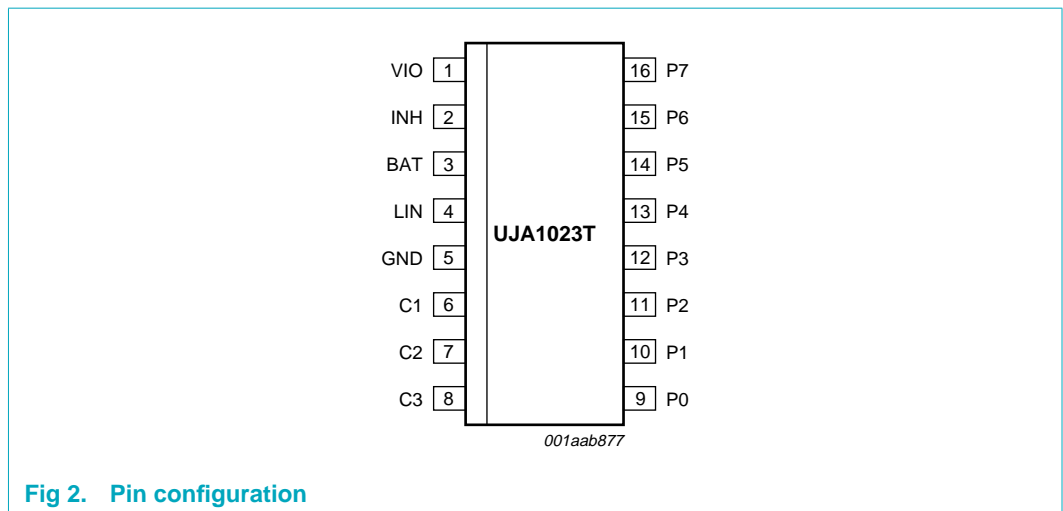

Fig 2. Pin configuration

6.2 Pin description

Table 3. Pin description

Symbol	Pin	Type ^[1]	Description
VIO	1	I	reference input for level adaptation of the I/O pins P0 to P7
INH	2	O	inhibit output for controlling an external voltage regulator or internal ADC
BAT	3	I	battery supply
LIN	4	I/O	LIN bus line
GND	5	I	ground
C1	6	I	configuration input 1 for LIN slave NAD assignment
C2	7	I	configuration input 2 for LIN slave NAD assignment
C3	8	I/O	configuration input / output 3 for LIN slave NAD assignment
P0	9	I/O	bidirectional I/O pin 0
P1	10	I/O	bidirectional I/O pin 1
P2	11	I/O	bidirectional I/O pin 2
P3	12	I/O	bidirectional I/O pin 3
P4	13	I/O	bidirectional I/O pin 4
P5	14	I/O	bidirectional I/O pin 5
P6	15	I/O	bidirectional I/O pin 6
P7	16	I/O	bidirectional I/O pin 7

[1] I = input;
O = output;
I/O = input or output.

7. Functional description

The UJA1023 combines all blocks necessary to work as a stand-alone LIN slave. Various I/O functions typically used in a car are supported. For a more detailed description refer to [Section 7.2](#) to [Section 7.6](#). The block diagram is shown in [Figure 1](#).

7.1 Short description of the UJA1023

7.1.1 LIN controller

The LIN 2.0 controller monitors and evaluates the LIN messages in order to process the LIN commands. It supervises and executes the NAD assignment, ID assignment and I/O-configuration and controls the operating modes of the UJA1023.

The NAD configuration is done by a combination of a LIN master request frame and a setting done by either a daisy chain or plug ID code.

7.1.2 LIN transceiver (including termination)

The LIN transceiver, which is LIN 2.0 / SAE J2602 compliant, is the interface between the internal LIN controller and the physical LIN bus. The transmit data stream of the LIN controller is converted into a bus signal with an optimized wave shape to minimize

electromagnetic emission. The required LIN slave termination of 30 k Ω is already integrated. In case of LIN bus faults the UJA1023 switches to the low-power Limp home mode.

7.1.3 Automatic bit rate detection

The automatic bit rate detection adapts to the LIN master's bit rate. Any bit rate between 1 kbit/s and 20 kbit/s can be handled. This block checks whether the synchronization break and synchronization field are valid. If not, the message will be rejected.

7.1.4 Oscillator

The on-chip oscillator provides the internal clock signal for some digital functions and is the time reference for the automatic bit rate detection.

7.1.5 I/O block

The I/O block controls the configuration of the I/O pins. The LIN master configures the I/O pin functionality by means of a master request frame and an optional slave response frame.

Besides the standard level input and output behavior the following functions are also handled by the UJA1023: local wake-up, cyclic input, edge capture, PWM output, switch matrix I/O and AD conversion.

7.1.6 ADC

With three external components an 8-bit ADC function can be implemented. Each of the eight bidirectional I/O pins can be used as input for the ADC, one at a time.

7.1.7 PWM

Each pin can be configured with a Pulse Width Modulation (PWM) function. The resolution is 8-bit and the base frequency is approximately 2.7 kHz.

7.1.8 Cyclic sense

To reduce current consumption, the cyclic sense function can be used to read a switch. The switch will be supplied and read back periodically.

7.2 LIN controller

7.2.1 Configuration

In this data sheet basic knowledge of the "*LIN diagnostic and configuration specification, Rev. 2.0*" is expected.

7.2.1.1 Message sequence

The UJA1023 conforms to the "*LIN diagnostic and configuration specification, Rev. 2.0*" and is compatible with LIN 1.3.

The UJA1023 can be configured via the LIN command frames 'Master Request' (MasterReq) and 'Slave Response' (SlaveResp). Both frames consist of eight data bytes. The MasterReq is used to send configuration data from the master to the slaves, whereas the slave being addressed by the prior MasterReq will answer with the related data on demand.

Depending on the usage of the MasterReq the meaning of the data bytes can be different. Thus each LIN slave evaluates these data bytes.

Using MasterReq and SlaveResp for the UJA1023 configuration flow, as shown in [Figure 3](#), is a so-called 'handshake' concept. The slave echoes its received MasterReq data in the SlaveResp, so the master can review slave configuration data. The use of the SlaveResp is optional.

The configuration flow is not disturbed if LIN commands other than shown in [Figure 3](#) are sent to other LIN slave nodes. Thus the LIN master can transmit other LIN messages while it (re)configures the UJA1023.

Remarks:

- The I/O configuration will be enabled during the first usage of the UJA1023 message frames (see [Section 7.2.5](#)) of the PxResp or PxReq
- Notation Px is used in this document when referring to a function or property of any of the I/O pins P0 to P7
- For correct I/O configuration, the configuration requests must be sent in sequential order of first, second and third configuration data block

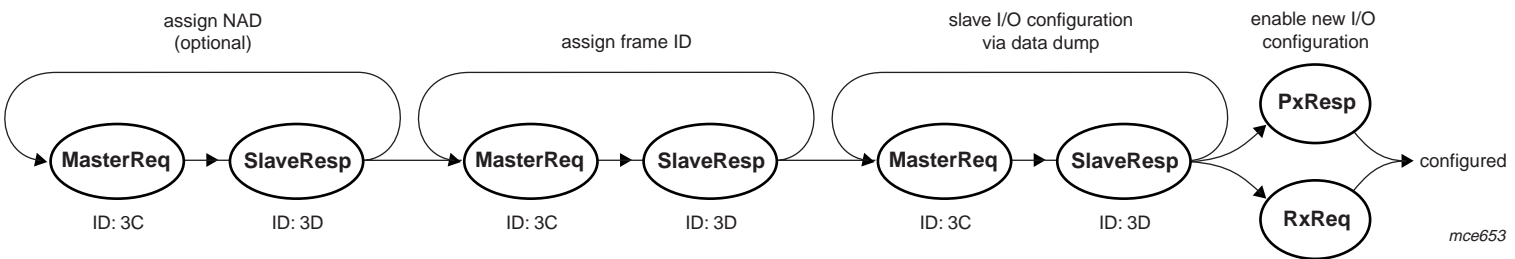

Fig 3. Typical configuration flow

7.2.1.2 LIN slave node address assignment

The default slave Node Address (NAD) after power-on depends on the input levels of the configuration pins C1, C2 and C3. These pins will be sampled directly after the power-on event. The relation between the configuration pins and the NAD is shown in [Table 4](#).

Table 4. Default NAD after power-on

Configuration pins			Default NAD (hex)
C3	C2	C1	
0	0	0	60
0	0	1	61
0	1	0	62
0	1	1	63
1	0	0	64
1	0	1	65
1	1	0	66
1	1	1	67

In case a different NAD is necessary the assign NAD command has to be used. The assign NAD request is carried out if the Service Identifier (SID) in the third data byte of the MasterReq is the assign NAD request and the fourth to seventh data bytes are the LIN supplier codes of Philips (0x0011) and UJA1023 function ID (0x0000).

Table 5. Data bytes of assign NAD request^[1]

Data byte	7	6	5	4	3	2	1	0	Default value (hex)
D0	d	d	d	d	d	d	d	d	08
D1	0	0	0	0	0	1	1	0	06
D2	1	0	1	1	0	0	0	0	B0
D3	0	0	0	1	0	0	0	1	11
D4	0	0	0	0	0	0	0	0	00
D5	0	0	0	0	0	0	0	0	00
D6	0	0	0	0	0	0	0	0	00
D7	NAD7	NAD6	NAD5	NAD4	NAD3	NAD2	NAD1	NAD0	NAD

[1] d = different values possible; see [Table 6](#).

Table 6. Bit description of assign NAD request

Byte	Bit	Symbol	Description
D0	7 to 0	C[3:1]	Initial NAD. This byte defines the initial NAD, refer to the related items topics <hr/> 0x08 to 0x0F (D0[0] = C1, D0[1] = C2 and D0[2] = C3) defines Plug ID; D0[3] = 1 for Plug ID configuration <hr/> 0x20 = daisy chain on; enable daisy chain pin drivers and receivers <hr/> 0x21 = assign NAD via daisy chain <hr/> 0x23 = daisy chain off; disable daisy chain pin drivers and receivers
D1	7 to 0	PCI	Protocol control information.
D2	7 to 0	SID	Service identifier. As SlaveResp the RSID code will be 0xF0.
D3 and D4	7 to 0	-	Supplier ID. Fixed code 0x0011 for Philips.
D5 and D6	7 to 0	-	Function ID. For the UJA1023 this code is fixed as 0x0000.
D7	7 to 0	NAD[7:0]	Slave Node Address (NAD). NAD values are in the range 1 to 127, while 0 and 128 to 255 are reserved for other purposes.

The format of the positive response is shown in [Table 7](#).

Table 7. Positive response assign NAD request^[1]

Data byte	7	6	5	4	3	2	1	0	Default value (hex)
D0	d	d	d	d	d	d	d	d	08
D1	0	0	0	0	0	0	0	1	01
D2	1	1	1	1	0	0	0	0	F0
D3	1	1	1	1	1	1	1	1	FF
D4	1	1	1	1	1	1	1	1	FF
D5	1	1	1	1	1	1	1	1	FF
D6	1	1	1	1	1	1	1	1	FF
D7	1	1	1	1	1	1	1	1	FF

[1] d = different values possible; see [Table 6](#).

The NAD assignment can be done via Daisy Chain (DC), (see [Section “Daisy chain NAD assignment”](#)) as well as via Plug ID (see [Section “Plug ID NAD assignment”](#)). The type of NAD assignment can be distinguished on the value of the initial NAD, which is the first data byte D0 of the MasterReq assign NAD request. For reliability reasons the assignment mode decision is valid only if the combination of D0 to D6 (see [Table 5](#)) is true. After power-on the UJA1023 message identifiers PxReq and PxResp (see [Section 7.2.5](#)) are disabled. This is also true for NAD reassignment. In this case the message identifiers PxReq, PxResp and I/O configuration are disabled.

Daisy chain NAD assignment: Once the UJA1023 receives the assign NAD MasterReq frame and the type of configuration is daisy chain, the following actions can take place, depending on the initial NAD value:

- Initial NAD 0x20: Daisy chain on, the C1 to C3 pin drivers are enabled
- Initial NAD 0x21: The input level on the configuration pin C1 and the status flag of the internal DC-switch is read. The UJA1023 will be configured if C1 is LOW and the DC-switch is open (see slave 2 in [Figure 4](#)). The UJA1023 under daisy chain configuration uses the data byte D7 as new NAD for its further LIN configuration requests (e.g. Assign Frame ID). After the NAD assignment the DC-switch at pin C3 is closed, which puts through the daisy chain signal to the next slave. The switch will be opened again as soon as an Assign NAD request with initial NAD daisy chain off has been received
- Initial NAD 0x23: Daisy chain off, the C1 to C3 pin drivers are disabled

After the NAD assignment, for example, the 'assign frame ID' can be used to assign specific ID numbers.

The internal pull-up resistors at pin C1 to C3 are active during the assign NAD process only. Thus it causes no permanent current (see also [Section 7.4](#)) and reduces power consumption especially in the low-power modes.

Remark: There is no slave response to assign NAD requests using the initial NAD 0x20 and NAD 0x23.

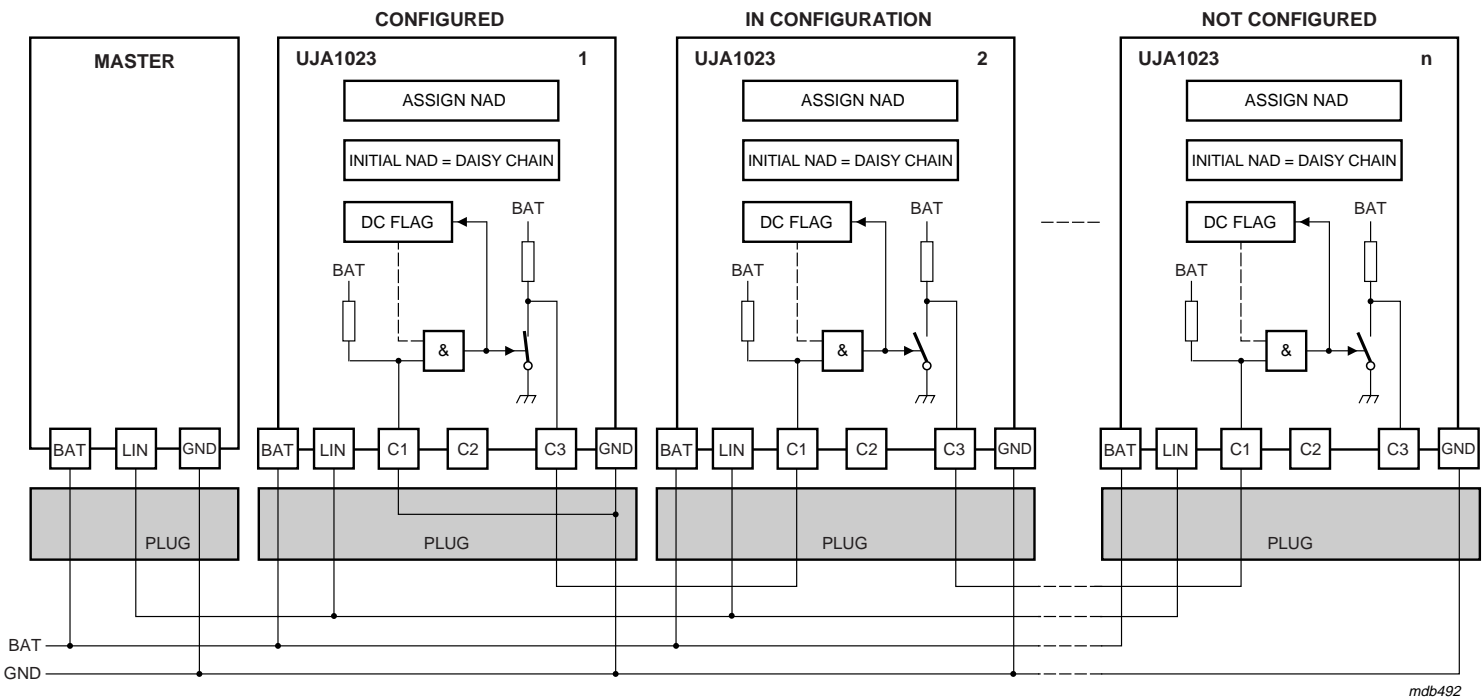
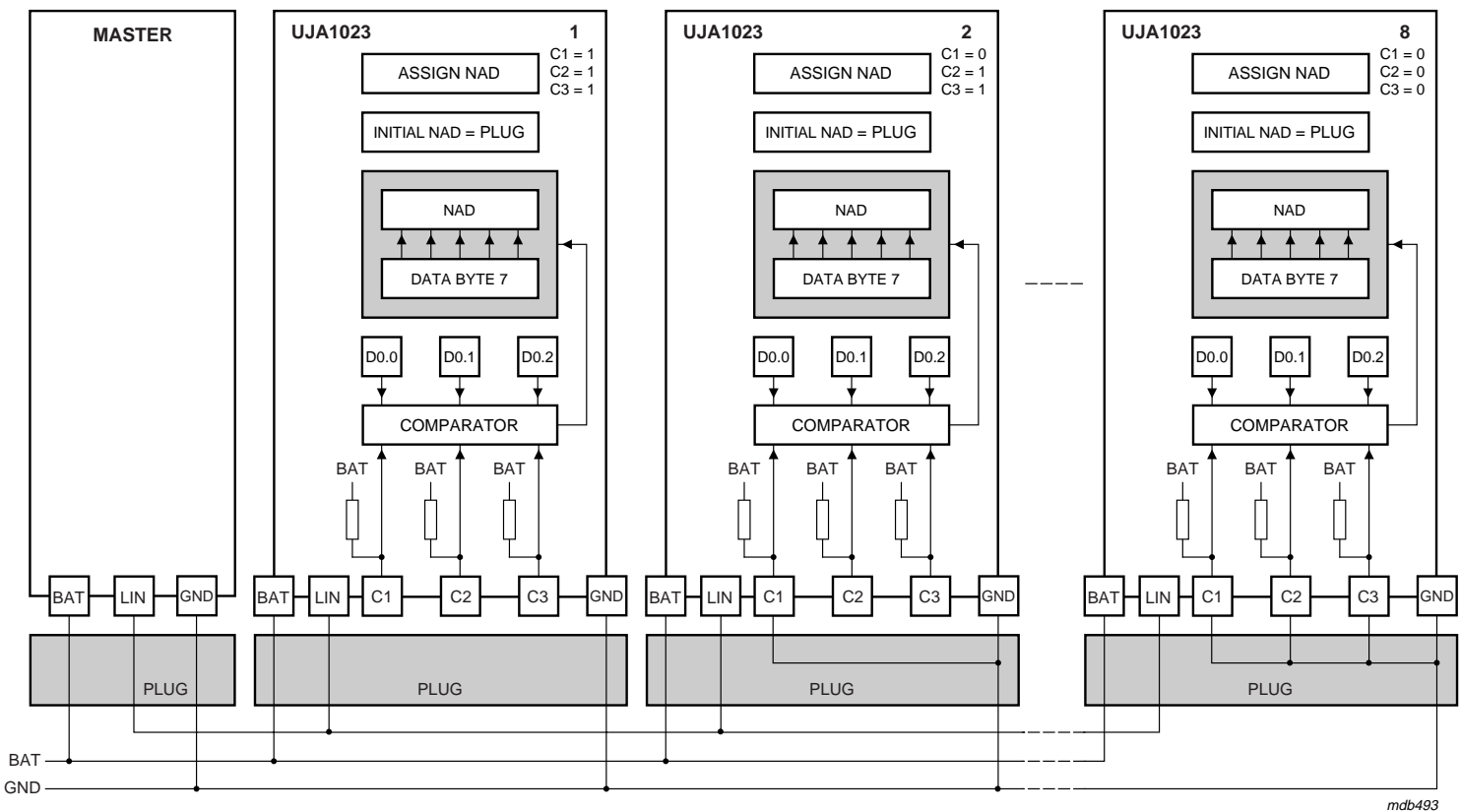

Fig 4. Daisy chain ID

Plug ID NAD assignment: Here the UJA1023 can be addressed via the pins C1, C2, and C3. Once the assign NAD MasterReq with the initial NAD 'Plug ID configuration' is received, the UJA1023 compares the values of the configuration pins C3, C2, and C1 with the values of the data bits D0[2:0]. If the values are equal and bits D0[7:4] are logic 0 and D0[3] is logic 1, the value of D7 is used as new NAD for the UJA1023.

Next, for example, the 'assign frame ID' can be used to assign specific ID numbers.

The internal pull-up resistors at pin C1 to C3 are active during the assign NAD process only. Thus it causes no permanent current (see also [Section 7.4](#)) and reduces power consumption especially in the low-power modes.



mdb493

Fig 5. Plug ID

7.2.1.3 Assign frame ID

By means of the assign frame ID command the LIN message identifier PxReq and PxResp can be changed to the desired values.

Table 8. Assign frame ID request bit allocation

Data byte	7	6	5	4	3	2	1	0	Default value (hex)
D0	NAD7	NAD6	NAD5	NAD4	NAD3	NAD2	NAD1	NAD0	NAD
D1	0	0	0	0	0	1	1	0	06
D2	1	0	1	1	0	0	0	1	B1
D3	0	0	0	1	0	0	0	1	11
D4	0	0	0	0	0	0	0	0	00
D5	0	0	0	0	0	0	0	0	00
D6	0	0	0	0	0	0	0	0	00
D7	ID7	ID6	ID5	ID4	ID3	ID2	ID1	ID0	protected ID

Table 9. Assign frame ID request bit description

Byte	Bit	Symbol	Description
D0	7 to 0	NAD[7:0]	Slave Node Address (NAD). NAD values are in the range from 1 to 127, while 0 and 128 to 255 are reserved for other purposes. The slave node address is assigned with the assign NAD command (see Table 5).
D1	7 to 0	PCI[7:0]	Protocol control information.
D2	7 to 0	SID[7:0]	Service identifier. As SlaveResp the RSID code will be 0xF1.
D3 and D4	7 to 0	-	Supplier ID. Fixed to 0x0011 for Philips.
D5 and D6	7 to 0	-	Message ID. Defines the assignment of the protected ID to PxResp and PxReq 0x0000: PxReq = protected ID; PxResp = protected ID + 1 0x0001: PxReq = unchanged; PxResp = protected ID 0x0002: PxReq = protected ID; PxResp = unchanged
D7	7 to 0	ID[7:0]	Protected ID. Defines the protected ID.

The format of the positive response is shown in [Table 10](#).

Table 10. Positive response assign frame ID

Data byte	7	6	5	4	3	2	1	0	Default value (hex)
D0	NAD7	NAD6	NAD5	NAD4	NAD3	NAD2	NAD1	NAD0	NAD
D1	0	0	0	0	0	0	0	1	01
D2	1	1	1	1	0	0	0	1	F1
D3	1	1	1	1	1	1	1	1	FF
D4	1	1	1	1	1	1	1	1	FF
D5	1	1	1	1	1	1	1	1	FF
D6	1	1	1	1	1	1	1	1	FF
D7	1	1	1	1	1	1	1	1	FF

7.2.1.4 Read by identifier

It is possible to read the supplier identifier, function identifier and the variant of the UJA1023 by means of the read by identifier request. The format for this request is shown in [Table 11](#). The positive response is shown in [Table 13](#), the negative response is shown in [Table 14](#).

Table 11. Read by identifier (LIN product identification)

Data byte	7	6	5	4	3	2	1	0	Default value (hex)
D0	NAD7	NAD6	NAD5	NAD4	NAD3	NAD2	NAD1	NAD0	NAD
D1	0	0	0	0	0	1	1	0	06
D2	1	0	1	1	0	0	1	0	B2
D3	0	0	0	0	0	0	0	0	00
D4	0	0	0	1	0	0	0	1	11
D5	0	0	0	0	0	0	0	0	00
D6	0	0	0	0	0	0	0	0	00
D7	0	0	0	0	0	0	0	0	00

Table 12. Read by identifier bit description

Byte	Bit	Symbol	Description
D0	7 to 0	NAD[7:0]	Slave Node Address (NAD). NAD values are in the range from 1 to 127, while 0 and 128 to 255 are reserved for other purposes. The slave node address is assigned with the assign NAD command (see Table 5).
D1	7 to 0	PCI[7:0]	Protocol control information.
D2	7 to 0	SID[7:0]	Service identifier. As SlaveResp the RSID code will be 0xF2 for a positive response and 0x7F for a negative response.
D3	7 to 1	-	Identifier. Only the LIN product identifier 0x00 is supported.
D4 and D5	7 to 0	-	Supplier ID. Fixed to 0x0011 for Philips.
D6 and D7	7 to 0	-	Function ID. For the UJA1023 this code is fixed to 0x0000.

Table 13. Read by identifier positive response^[1]

Data byte	7	6	5	4	3	2	1	0	Default value (hex)
D0	NAD7	NAD6	NAD5	NAD4	NAD3	NAD2	NAD1	NAD0	NAD
D1	0	0	0	0	0	1	1	0	06
D2	1	1	1	1	0	0	1	0	F2
D3	0	0	0	1	0	0	0	1	11
D4	0	0	0	0	0	0	0	0	00
D5	0	0	0	0	0	0	0	0	00
D6	0	0	0	0	0	0	0	0	00
D7	d	d	d	d	d	d	d	d	variant

[1] d = different values possible; see [Table 12](#).

Table 14. Read by identifier negative response

Data byte	7	6	5	4	3	2	1	0	Default value (hex)
D0	NAD7	NAD6	NAD5	NAD4	NAD3	NAD2	NAD1	NAD0	NAD
D1	0	0	0	0	0	0	1	1	03
D2	0	1	1	1	1	1	1	1	7F
D3	1	0	1	1	0	0	1	0	B2
D4	0	0	0	1	0	0	1	0	12
D5	1	1	1	1	1	1	1	1	FF
D6	1	1	1	1	1	1	1	1	FF
D7	1	1	1	1	1	1	1	1	FF

7.2.1.5 I/O configuration

The I/O configuration is done via the LIN configuration request 'Data Dump', where the first data byte of the MasterReq contains the slave node address NAD. The I/O-pin configuration process starts only, if the received slave node address matches the own UJA1023 node address and if data byte D2 (SID) is 0xB4.

As with the other configuration commands, the master transmits the I/O-pin configuration data via the MasterReq message. Due to the limited amount of data bytes within the LIN configuration command 'Data Dump', the configuration and diagnosis is split-up into four blocks. The configuration and diagnosis blocks are distinguished on bits 6 and 7 of data byte D3. The master can review the new configuration data via the SlaveResp message. Finally if the master considers the received configuration data of the LIN-I/O to be correct, it can enable the slave I/O-configuration by using the UJA1023 message frames (see [Section 7.2.5](#)) PxResp or PxReq.

It should be noted that for correct I/O configuration, the configuration requests must be sent in sequential order of: first, second and third configuration data block.

Table 15. First I/O configuration data block bit allocation

Data byte	7	6	5	4	3	2	1	0	Default value (hex)
D0	NAD7	NAD6	NAD5	NAD4	NAD3	NAD2	NAD1	NAD0	NAD
D1	0	0	0	0	0	1	1	0	06
D2	1	0	1	1	0	1	0	0	B4
D3	0	0	IM1	IM0	RxDL	ADCIN2	ADCIN1	ADCIN0	00
D4	HSE7	HSE6	HSE5	HSE4	HSE3	HSE2	HSE1	HSE0	00
D5	LSE7	LSE6	LSE5	LSE4	LSE3	LSE2	LSE1	LSE0	00
D6	OM0_7	OM0_6	OM0_5	OM0_4	OM0_3	OM0_2	OM0_1	OM0_0	00
D7	OM1_7	OM1_6	OM1_5	OM1_4	OM1_3	OM1_2	OM1_1	OM1_0	00

Table 16. First I/O configuration data block bit description

Byte	Bit	Symbol	Description
D0	7 to 0	NAD[7:0]	Slave node address (NAD). NAD values are in the range from 1 to 127, while 0 and 128 to 255 are reserved for other purposes. The slave node address is assigned with the assign NAD command (see Table 5).
D1	7 to 0	PCI[7:0]	Protocol control information.
D2	7 to 0	SID[7:0]	Service identifier. As SlaveResp the RSID value will be 0xF4.
D3	7 and 6	-	00 for first configuration data block.
	5 and 4	IM[1:0]	Pin INH mode. Mode will be changed after PxReq or PxResp 00 = external regulator (control of external voltage regulator) 01 = ADC 10 = reserved, if selected both bits will be logic 1 11 = switch open
	3	RxDL	Receive data length. Message PxReq contains two data bytes if RxDL = 0 and three data bytes if RxDL = 1.
	2 to 0	ADCIN[2:0]	Analog source channel selection. The number of ADCIN[2:0] determines which of the P7 to P0 input is used. For example if ADCIN[2:0] = 101 then P5 will be the input. ADCIN[2:0] is used only if ADC mode is selected (IM[1:0] = 01) and RxDL = 0 (No analog input selection at PxReq).
D4	7 to 0	HSE[7:0]	High-side enable for I/O pin Px.
D5	7 to 0	LSE[7:0]	Low-side enable for I/O pin Px.
D6 and D7	7 to 0	OM0_[7:0], OM1_[7:0]	Output mode for I/O pin Px.
			OM1_x OM0_x
			0 0 level
			0 1 reserved
			1 0 cyclic sense
1 1 PWM			

The second configuration data block (shown in [Table 17](#)) is selected only if D3.7 = 0 and D3.6 = 1.

Table 17. Second I/O configuration data block bit allocation

Data byte	7	6	5	4	3	2	1	0	Default value (hex)
D0	NAD7	NAD6	NAD5	NAD4	NAD3	NAD2	NAD1	NAD0	NAD
D1	0	0	0	0	0	1	1	0	06
D2	1	0	1	1	0	1	0	0	B4
D3	0	1	LSLP	TxDL	SMC	SMW	SM1	SM0	40
D4	CM0_7	CM0_6	CM0_5	CM0_4	CM0_3	CM0_2	CM0_1	CM0_0	00
D5	CM1_7	CM1_6	CM1_5	CM1_4	CM1_3	CM1_2	CM1_1	CM1_0	00
D6	TH2/TH1	TH2/TH1	TH2/TH1	TH2/TH1	TH2/TH1	TH2/TH1	TH2/TH1	TH2/TH1	00
D7	LWM7	LWM6	LWM5	LWM4	LWM3	LWM2	LWM1	LWM0	00

Table 18. Second I/O configuration data block bit description

Byte	Bit	Symbol	Description
D0	7 to 0	NAD[7:0]	Slave node address (NAD). NAD values are in the range from 1 to 127, while 0 and 128 to 255 are reserved for other purposes. The slave node address is assigned with the assign NAD command (see Table 5).
D1	7 to 0	PCI[7:0]	Protocol control information.
D2	7 to 0	SID[7:0]	Service identifier. As SlaveResp the RSID value will be 0xF4.
D3	7 and 6	-	01 for the second configuration data block.
	5	LSLP	Limp home sleep mode. If LSLP = 1, the Limp home sleep mode is enabled. In this case the Limp Home value (LH) is automatically used as output value if the Sleep mode is entered.
	4	TxDL	Transmit data length. Message PxResp contains two data bytes if TxDL = 0 and four data bytes if TxDL = 1.
	3	SMC	Switch matrix capture. If SMC = 1, the Switch matrix capture mode is enabled.
	2	SMW	Switch matrix wake-up. If SMW = 1, the switch matrix wakes up upon changed input level.
	1 and 0	SM[1:0]	Switch matrix enable
			00 = no switch matrix 01 = 4 × 2: P3 to P0 input and P5 and P4 strong pull down 10 = 4 × 3: P3 to P0 input and P6 to P4 strong pull down 11 = 4 × 4: P3 to P0 input and P7 to P4 strong pull down
			Unassigned pins can be used as I/O. It should be noted, however, that for the unassigned pins, which are configured in Capture mode, the captured edge value will not be transferred.

Table 18. Second I/O configuration data block bit description ...continued

Byte	Bit	Symbol	Description		
D4 and D5	7 to 0	CM0_[7:0], CM1_[7:0]	Capture mode for I/O pin Px.		
			CM1_x	CM0_x	
			0	0	no capture
			0	1	falling edge
			1	0	rising edge
			1	1	both edges
D6	7 to 0	TH2 and TH1	Threshold select. If logic 0 (= TH1), selects V_{th1} as input threshold. If logic 1 (= TH2) selects V_{th2} as input threshold, except in Cyclic sense mode, then V_{th3} is selected.		
D7	7 to 0	LWM_[7:0]	Local wake-up mask. If LWM_x = 1, the corresponding Px pin is configured as local wake-up pin. LWM_x is ignored if Px is configured as switch matrix.		

Table 19 shows the third configuration data block, that is used to define the slope of the transmitter, selection between classic or enhanced checksum model, limp home output value and PWM initial value. It is selected only if D3.7 = 1 and D3.6 = 0.

Table 19. Third I/O configuration data block bit allocation

Data byte	7	6	5	4	3	2	1	0	Default value (hex)
D0	NAD7	NAD6	NAD5	NAD4	NAD3	NAD2	NAD1	NAD0	NAD
D1	0	0	0	0	0	1	0	0	04
D2	1	0	1	1	0	1	0	0	B4
D3 ^[1]	1	0	r	r	r	r	LSC	ECC	80
D4	LH7	LH6	LH5	LH4	LH3	LH2	LH1	LH0	00
D5	PWM7	PWM6	PWM5	PWM4	PWM3	PWM2	PWM1	PWM0	00
D6	1	1	1	1	1	1	1	1	FF
D7	1	1	1	1	1	1	1	1	FF

[1] r = reserved, must be '0'.

Table 20. Third I/O configuration data block bit description

Byte	Bit	Symbol	Description
D0	7 to 0	NAD[7:0]	Slave node address (NAD). NAD values are in the range from 1 to 127, while 0 and 128 to 255 are reserved for other purposes. The slave node address is assigned with the assign NAD command (see Table 5).
D1	7 to 0	PCI[7:0]	Protocol control information.
D2	7 to 0	SID[7:0]	Service identifier. As SlaveResp the RSID value will be 0xF4.

Table 20. Third I/O configuration data block bit description ...continued

Byte	Bit	Symbol	Description
D3	7 and 6	-	10 for the third configuration data block.
	5 to 2	-	Reserved. Must be 0.
	1	LSC	LIN slope control
			0 = up to 20 kbit/s (default) 1 = up to 10.4 kbit/s
0	ECC	Enhanced checksum control	
		0 = classic checksum (default) 1 = enhanced checksum	
D4	7	LH[7:0]	Limp home value. Output value in Limp home and Limp home sleep mode.
D5	7 to 0	PWM[7:0]	PWM initial value.
D6 and D7	7 to 0	-	Not used.

[Table 21](#) shows the fourth data block, that is selected if D3.6 = 1 and D3.7 = 1. It is not used for I/O-pin configuration but to provide the master with diagnosis data of the UJA1023. It is a read-only data block. If the slave node address matches and the fourth data block is selected, the UJA1023 transmits its diagnosis data via the SlaveResp message.

Table 21. Fourth I/O diagnostic data block request frame bit allocation

Data byte	7	6	5	4	3	2	1	0	Default value (hex)
D0	NAD7	NAD6	NAD5	NAD4	NAD3	NAD2	NAD1	NAD0	NAD
D1	0	0	0	0	0	0	1	0	02
D2	1	0	1	1	0	1	0	0	B4
D3	1	1	0	0	0	0	0	0	C0
D4	1	1	1	1	1	1	1	1	FF
D5	1	1	1	1	1	1	1	1	FF
D6	1	1	1	1	1	1	1	1	FF
D7	1	1	1	1	1	1	1	1	FF

Table 22. Fourth I/O diagnostic data block request frame bit description

Byte	Bit	Symbol	Description
D0	7 to 0	NAD[7:0]	Slave node address (NAD). NAD values are in the range from 1 to 127, while 0 and 128 to 255 are reserved for other purposes. The slave node address is assigned with the assign NAD command (see Table 5).
D1	7 to 0	PCI[7:0]	Protocol control information.
D2	7 to 0	SID[7:0]	Service identifier.
D3	7 and 6	-	11 for the fourth configuration data block.
	5 to 0	-	Not used.
D4 to D7	7 to 0	-	Not used.

Table 23. Fourth I/O diagnostic data block response frame bit allocation

Data byte	7	6	5	4	3	2	1	0	Default value (hex)
D0	NAD7	NAD6	NAD5	NAD4	NAD3	NAD2	NAD1	NAD0	NAD
D1	0	0	0	0	0	1	0	0	04
D2	1	1	1	1	0	1	0	0	F4
D3	1	1	0	0	0	0	0	0	C0
D4	P	RxB	CS	TxB	u ^[1]	NVM	LHE	ERR	00
D5	PL7	PL6	PL5	PL4	PL3	PL2	PL1	PL0	00
D6	1	1	1	1	1	1	1	1	FF
D7	1	1	1	1	1	1	1	1	FF

[1] Undefined.

Table 24. Fourth I/O diagnostic data block response frame bit description

Byte	Bit	Symbol	Description
D0	7 to 0	NAD[7:0]	Slave node address (NAD). NAD values are in the range from 1 to 127, while 0 and 128 to 255 are reserved for other purposes. The slave node address is assigned with the assign NAD command (see Table 5).
D1	7 to 0	PCI[7:0]	Protocol control information.
D2	7 to 0	RSID[7:0]	Response service identifier.
D3	7 and 6	-	11 for the fourth configuration data block.
	5 to 0	-	Not used.
D4 ^[1]	7	P	Parity error. Set if identifier parity bits are erroneous.
	6	RxB	Receive error. Set if start or stop bits are erroneous during reception.
	5	CS	Checksum error. Set if checksum is erroneous.
	4	TxB	Transmit error. Set if start, data or stop bits are erroneous during transmission.
	3	undefined	-
	2	NVM	No valid message. Set if there is bus activity, but no valid message frame for longer than $t_{to(idle)}$.
	1	LHE	Set if Limp home mode is entered.
	0	ERR	Response error. Sets internal signal Response_Error if there is an RxB, CS or TxB during a response frame.
D5	7 to 0	PL[7:0]	PxOut latch value.
D6 and D7	7 to 0	-	Not used.

[1] All diagnosis flags in byte D4 are reset after data access from master.

7.2.1.6 Configuration examples

Example 1, UJA1023 configuration with eight low-side outputs.

```
//
//Example 8 LSE and walking '1' pattern
//C1, C2 and C3 are GND
//SB = SyncBreak; SF = SyncField
//
SB SF 3C 60 06 B1 11 00 00 00 04 D2 // Assign frameID, default NAD used and
// ID(PxReq) = 04, ID(PxResp) = 05
SB SF 7D 60 01 F1 FF FF FF FF FF AC // Positive response
SB SF 3C 60 06 B4 00 00 FF 00 00 E4 // Datadump1, 8 x LSE
SB SF 7D 60 06 F4 00 00 FF 00 00 A4 // Read back configuration sent
SB SF 3C 60 06 B4 40 00 00 00 00 A4 // Datadump2, no capture and
// threshold select (optional)
SB SF 7D 60 06 F4 40 00 00 00 00 64 // Read back configuration sent
SB SF 3C 60 04 B4 80 55 10 FF FF 01 // Data dump3, LH value = 0x55, default
// PWM = 0x10 (optional)
SB SF 7D 60 04 F4 80 55 10 FF FF C0 // Read back configuration sent
SB SF 3C 60 06 B2 00 11 00 00 00 D5 // Read by identifier request (optional)
SB SF 7D 60 06 F2 11 00 00 00 02 93 // Positive response
SB SF C4 01 80 7E // IO configuration enabled and low-side
// switch P0 on
SB SF C4 02 80 7D // Low-sideswitch P1 on
SB SF C4 04 80 7B // Low-sideswitch P2 on
SB SF C4 08 80 77 // Low-sideswitch P3 on
SB SF C4 10 80 6F // Low-sideswitch P4 on
SB SF C4 20 80 5F // Low-sideswitch P5 on
SB SF C4 40 80 3F // Low-sideswitch P6 on
SB SF C4 80 80 FE // Low-sideswitch P7 on
```

Example 2, UJA1023 configuration with eight inputs and edge capture.

```

//
//Example 8 inputs with capture
//C1, C2 and C3 are GND
//SB = SyncBreak; SF = SyncField
//
SB SF 3C 60 06 B1 11 00 00 00 04 D2 // Assign frameID, default NAD used and
// ID(PxReq) = 04, ID(PxResp) = 05
SB SF 7D 60 01 F1 FF FF FF FF FF AC // Positive response
SB SF 3C 60 06 B4 00 00 00 00 00 E4 // Datadump1, all outputs disabled (optional)
SB SF 7D 60 06 F4 00 00 00 00 00 A4 // Read back configuration sent
SB SF 3C 60 06 B4 40 FF FF 00 FF A4 // Datadump2, all both edge capture and
// inputs as wake-up
SB SF 7D 60 06 F4 40 FF FF 00 FF 64 // Read back configuration sent
SB SF 3C 60 04 B4 80 55 10 FF FF 01 // Data dump3, LH value = 0x55, default
// PWM = 0x10 (optional)
SB SF 7D 60 04 F4 80 55 10 FF FF C0 // Read back configuration sent
SB SF 3C 60 06 B2 00 11 00 00 00 D5 // Read by identifier request (optional)
SB SF 7D 60 06 F2 11 00 00 00 02 93 // Positive response
SB SF 85 00 00 FF // IO configuration enabled and read inputs
SB SF 80 // Dummy message
SB SF 80 // Dummy message and input 0 changes
SB SF 85 01 01 FD // Input 0 set and edge detected
SB SF 80 //
SB SF 85 01 00 FE // Input 0 still set

```

7.2.2 Operating modes

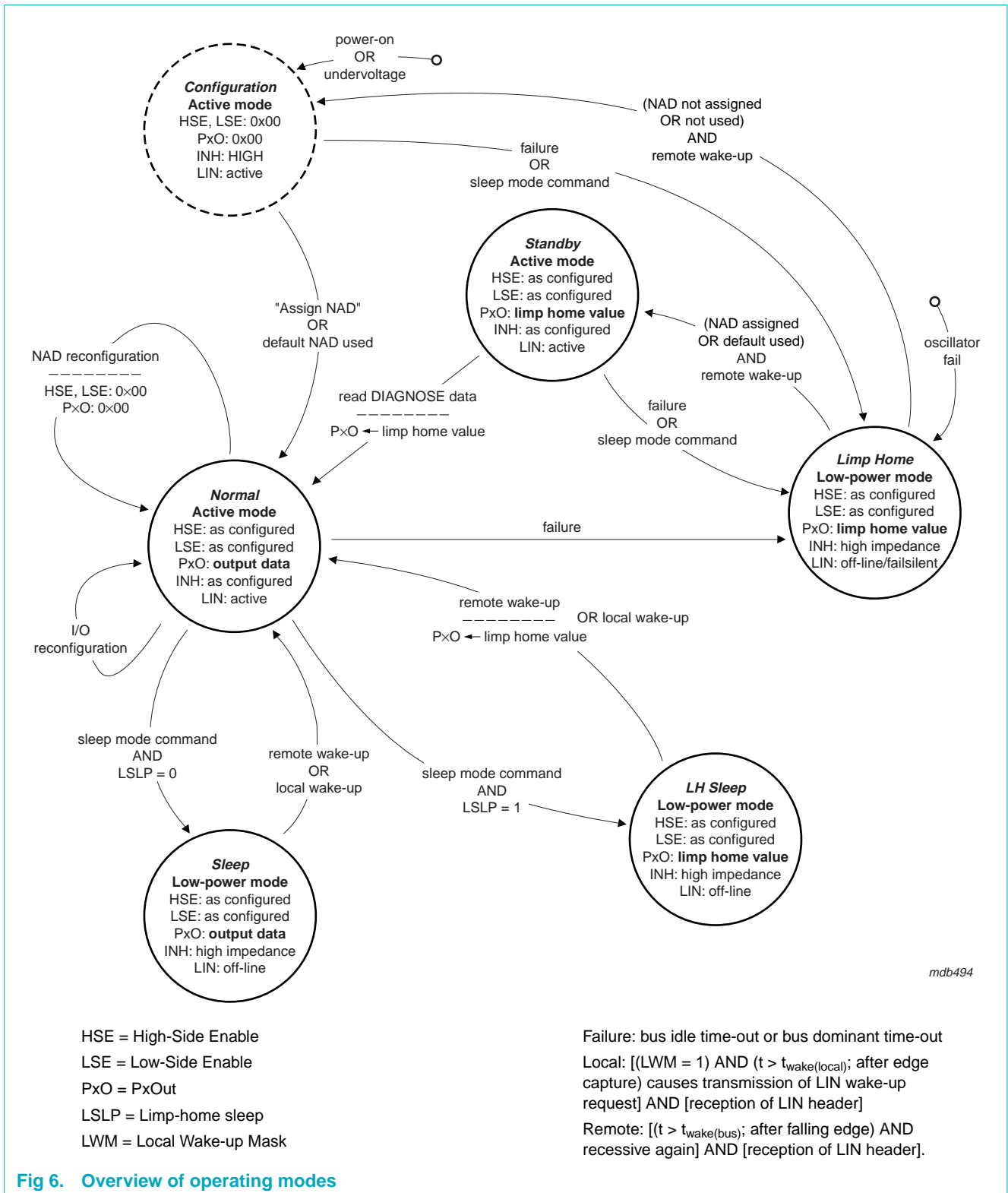

mdb494

HSE = High-Side Enable
 LSE = Low-Side Enable
 PxO = PxOut
 LSLP = Limp-home sleep
 LWM = Local Wake-up Mask

Failure: bus idle time-out or bus dominant time-out
 Local: [(LWM = 1) AND (t > t_{wake(local)}); after edge capture] causes transmission of LIN wake-up request] AND [reception of LIN header]
 Remote: [(t > t_{wake(bus)}); after falling edge] AND [recessive again] AND [reception of LIN header].

Fig 6. Overview of operating modes

7.2.2.1 Configuration mode

The Configuration mode can be seen as initial state after power-on or undervoltage detection. The UJA1023 configuration values are in the default settings. The I/O pins P0 to P7 (Px) are set to high-impedance behavior and the INH is in its External regulator mode, which outputs a HIGH-level in order to switch on an external voltage regulator.

In Configuration mode the UJA1023 is not configured and it has no valid identifier and, depending on the configuration pins, a default NAD. Thus, with the exception of the MasterReq command, all LIN slave commands are disabled. Once the UJA1023 NAD is assigned, via the assign NAD request, or the default NAD is used for the first time, the Normal mode is entered. If a LIN bus failure is present (bus idle time-out or bus dominant time-out) or the sleep command has been received, the UJA1023 enters its low-power (Limp home) mode.

7.2.2.2 Normal mode

In Normal mode the UJA1023 receives and/or transmits input/output data as well as configuration data.

A UJA1023 in Configuration mode enters the Normal mode only after its NAD assignment or the first usage of the default NAD. After a NAD reconfiguration, all ports that are configured in Output mode will be set to high-impedance.

Coming from Sleep mode or Limp home sleep mode the Normal mode can be entered via local or remote wake-up. The output register of each I/O pin P0 to P7 (PxOut) keeps its values of the Sleep mode or Limp home sleep mode. If the INH is in External regulator mode, it outputs a HIGH-level to switch on an external voltage regulator.

For a mode transition from Standby mode to Normal mode the diagnostic data must be read via a SlaveResp. With this request the master acknowledges the previous failure. The PxOut registers keep their limp home values.

7.2.2.3 Sleep mode

The UJA1023 enters its Sleep mode when the 'Sleep mode command' has been received and the limp home sleep bit LSLP is reset ($LSLP = 0$). In Sleep mode the UJA1023 keeps the current status on its Px. The INH will switch to high-impedance state.

After a local wake-up event the UJA1023 sends a 'wake-up signal' to wake up the master. In Sleep mode the PWM and ADC are reset. The first LIN message will be lost due to waking up the UJA1023.

7.2.2.4 Limp home sleep mode

Some applications may need dedicated HIGH and/or LOW output levels during Sleep mode in order to achieve the lowest power dissipation of the application. Therefore the UJA1023 provides the Limp home sleep mode (LH sleep mode). By enabling the LSLP bit, the LH sleep mode output behavior can be configured. The LH sleep mode is enabled if the configuration bit LSLP (D3.5) is set ($LSLP = 1$, see [Table 18](#)).

After a local wake-up event the UJA1023 sends a 'wake-up signal' to wake up the master. In the LH sleep mode the output registers (PxOut) of the UJA1023 are loaded with the limp home value. After a wake-up event (local or remote wake-up) the PxOut keep their limp home value.

In LH sleep mode the PWM and ADC are reset. The first LIN message will be lost due to waking up the UJA1023.

7.2.2.5 Limp home mode and Standby mode

Limp home mode and Standby mode differ in the output of pin INH if the INH is configured in External regulator mode. Where in Limp home mode pin INH is high-impedance and in Standby mode pin INH is HIGH. In contrast to the Standby mode the Limp home mode is a low-power mode.

The limp home value specifies the PxOut values in case LIN bus communication fails. The Px configuration push-pull, open-drain or high-impedance keeps unchanged in Limp home mode.

The Limp home mode will be entered from Normal mode if the LIN bus is short-circuited to ground for a time exceeding the bus dominant time-out ($t_{to(dom)}$) or if the bus idle time-out ($t_{to(idle)}$) expires.

Coming from Limp home mode the Standby mode is entered after remote wake-up if the UJA1023 is configured. In case the UJA1023 is not configured, it enters the Configuration mode after remote wake-up.

In Standby and Configuration mode the UJA1023 enters the Limp home mode again if the configuration fails or if the 'Sleep mode command' has been received.

7.2.3 I/O pin modes

7.2.3.1 Input

Inputs can always be read via a PxResp frame (see [Section 7.2.5](#)). The input threshold is determined by the TH bits in the second I/O configuration block (see [Table 17](#)).

7.2.3.2 Level mode

In Level mode the PxOut register of the UJA1023 can be set or reset. Depending on the Px configuration the PxOut value is output.

7.2.3.3 PWM mode

The PWM mode provides a PWM signal with 8-bit resolution to the I/O-stage. The base frequency is typically 700 kHz divided by 256 (8-bit) and becomes approximately 2.7 kHz. The mode is entered via both mode configuration bits OM0 and OM1. The PWM signal is common for all assigned outputs.

In the low-power modes (Sleep mode, LH sleep mode and Limp home mode) the PWM value is reset (PWM = 0x00) and the previous PWM value is lost.

7.2.3.4 Cyclic sense mode

The Cyclic sense mode is used to supply and read back external switches. In this mode the Px pin is configured as a switched supply to reduce the power consumption. It is primarily intended to supply wake-up switches.

A Px pin in Cyclic sense mode has to be configured with the High-Side Enable register (HSE) in HIGH-state and the Low-Side Enable register (LSE) in LOW-state. The PxOut flip-flop is being cyclically switched (see [Figure 7](#)).

The Cyclic sense mode can be configured via the Output mode bits OM0 and OM1 in the configuration data bytes (see [Table 16](#)). In case threshold TH2 is selected then threshold TH3 will be used instead. This feature is used for diagnosis purposes to check the presence of a switch with an integrated parallel resistor (typical value is $2800 \Omega \pm 1 \%$). The switch can be detected by selecting first TH1 and then TH2.

All Px pins in Cyclic sense mode are sampled simultaneously. The Cyclic sense mode timing is specified in [Section 11](#). No wake-up will occur when the local wake-up mask is set and Sleep mode is entered when the Px pin is LOW. A wake-up will be issued when in Sleep mode and the Px input level changes.

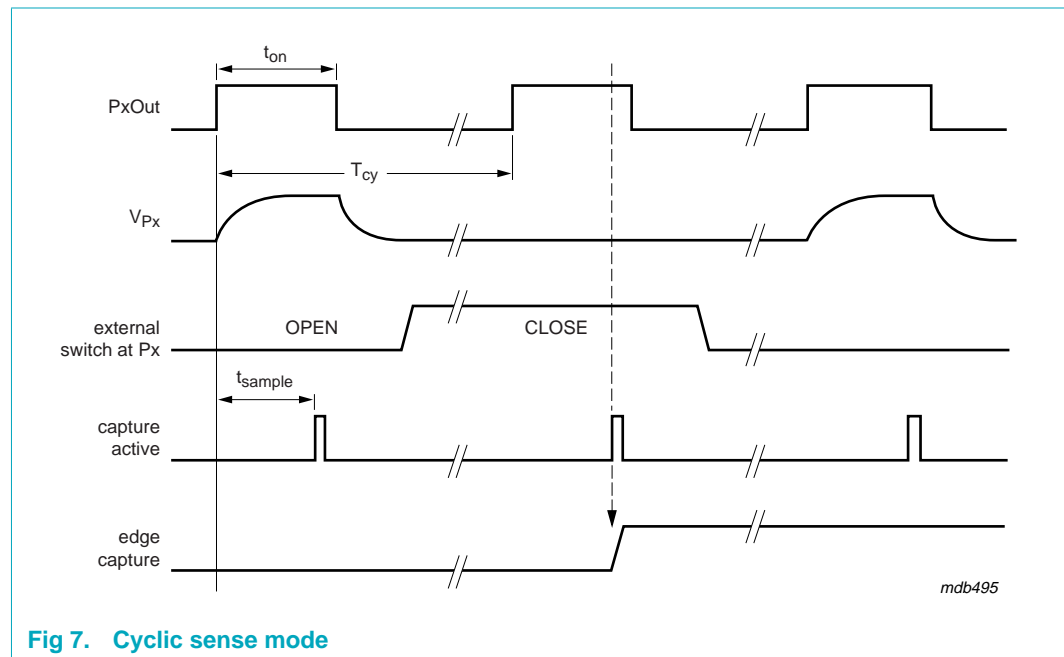

Fig 7. Cyclic sense mode

7.2.3.5 Switch matrix mode

[Figure 8](#) shows an application example of a 4×4 switch matrix with the UJA1023. The drive capability of the I/O-pins Px supports the use of a 4×4 switch matrix without extra components. The I/O pins from P0 to P3 provide a weak but sufficient pull-up for switch applications and the pins from P4 to P7 are used as strong pull-down in case a switch is pushed.

The Switch matrix mode can be enabled for the I/O-pins Px via data byte D3 of the second configuration data block (see [Table 18](#)).

The data bits SM0 and SM1 configure P0 to P3 as an input with a weak but sufficient pull-up for switch applications and P4 to P7 as strong pull-down in order to detect an activated switch (see [Table 18](#)).

In Normal mode when a valid sync break and sync field is received, automatically a matrix scan starts:

- Immediately if the slave is not addressed
- When addressed, after the LIN message is handled

This means that the scan matrix value is determined directly after the previous LIN message.

In case two or more switches are closed simultaneously, extra diodes have to be added to prevent the 'short-circuit' of neighbor switches.

For the switch matrix inputs a 'quasi' capture mode can be configured via the data bit SMC (D3.3) of the second configuration block. If a matrix switch input value has been changed the changed value is captured until the master reads the switch matrix value via the UJA1023 command PxResp. Note that two readings are necessary for proper initialization.

A switch matrix can be configured as local wake-up. If the data bit SMW (D3.2) of the second configuration block is set to logic 1, a change of a matrix switch input value causes a wake-up of the UJA1023. If in addition the Switch matrix capture mode is enabled via SMC the switch matrix value of PxResp represents the local wake-up source switch of the switch matrix.

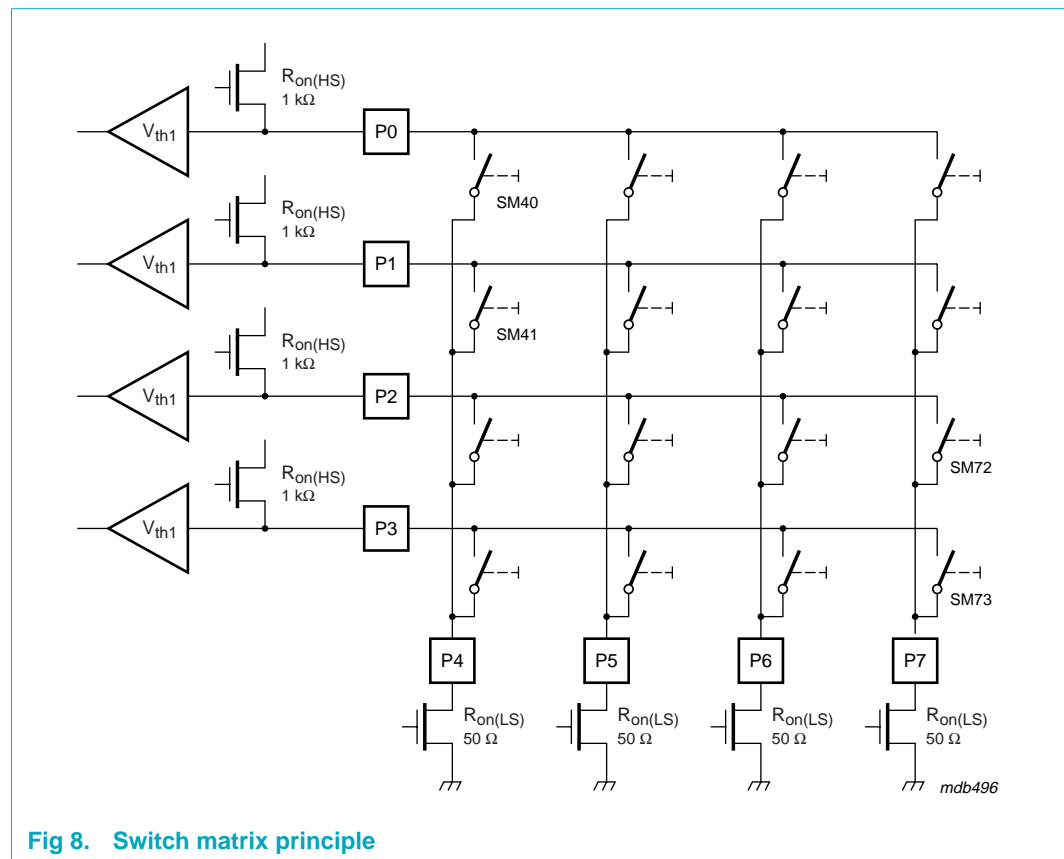

Fig 8. Switch matrix principle

7.2.3.6 ADC mode

The principle of the bit stream ADC is shown in Figure 9. Only three external components are needed per analog input, which should be dimensioned as: $R_i = R_1 = 100\text{ k}\Omega$; $C_1 = 10\text{ nF}$. All eight inputs can be used as analog input, one at a time. ADC values are referenced to V_{VIO} . A register/counter is used to count the ratio of HIGH and LOW phases of the bit stream. This ratio represents the analog voltage V_A . The upper counter is used to define the measurement period, typically 1.5 ms.

The inverted bit stream of the ADC comparator generates the quasi-analog output voltage on pin INH, which can be used to control the analog voltage V_A via a low-pass filter.

An analog-to-digital conversion will have following steps:

1. Select an input channel via PxReq, see [Section 7.2.5](#). Not needed in case a fixed ADC-input is selected (see [Table 16](#) for RxDL = 0 and ADCIN[2:0]).
2. The internal multiplexer switches over to the selected input; note that some time is needed to stabilize the loop, due to the RC network time constant.
3. In case a valid sync break and sync field is received, an analog-to-digital conversion starts. The data is available in the next LIN message, implying the ADC value is sampled during the **previous** LIN message.

To reduce current consumption, the $0.5V_{VIO}$ reference voltage is turned off in the low-power modes.

7.2.4 INH pin mode

The External regulator mode, IM0 = IM1 = 0 (see [Table 16](#)), can be used to control an external voltage regulator. In Configuration mode, Normal mode and Standby mode the INH outputs a HIGH level, and in the low-power modes (Sleep, LH sleep and Limp home) the INH pin becomes high-impedance.

Switching between the INH modes 'external regulator' and 'switch open' the INH pin can be used as high-side switch.

In ADC mode the INH pin is configured internally as follows: the high-side switch is put in high-impedance state and a special symmetrical push-pull output is activated. Next, the ADC mode enables an ADC control loop. The output level of the push-pull stage is defined via the V_{VIO} voltage.

7.2.5 LIN-I/O message frames

The UJA1023 uses one LIN command to receive data PxReq and one to transmit data PxResp respectively. The IDs for PxReq and PxResp are configured by means of the 'assign frame ID' command as described in [Section 7.2.1.3](#).

Please note that the I/O configuration will be enabled during the first usage of the PxResp or PxReq.

The PxReq and PxResp data bytes are described in [Table 25](#) to [Table 28](#).

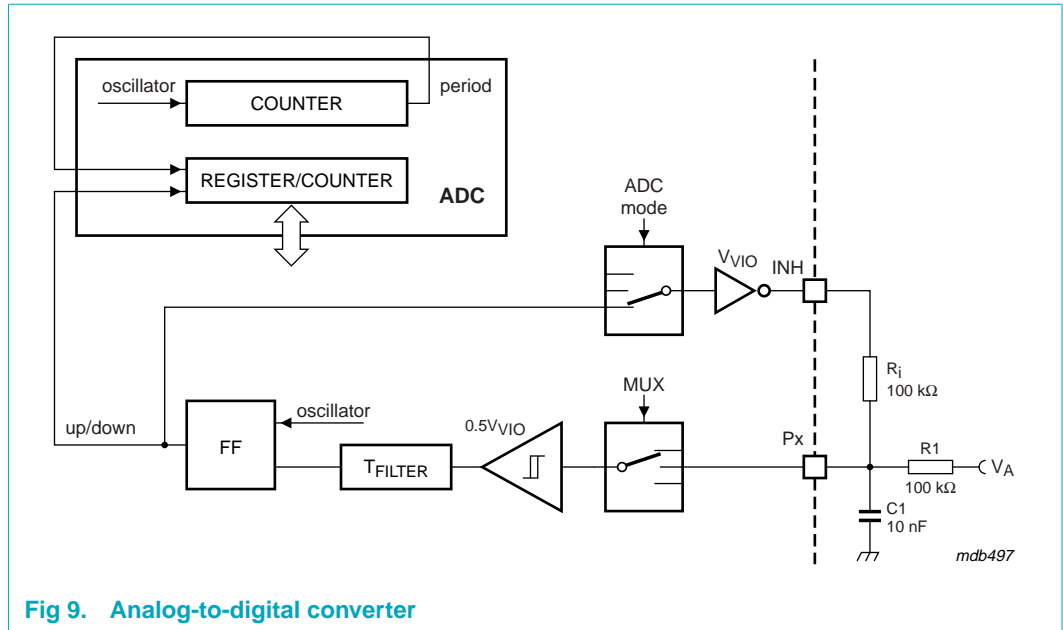

Fig 9. Analog-to-digital converter

Table 25. PxReq frame bit allocation

Data byte	7	6	5	4	3	2	1	0	Default value (hex)
D0	P7	P6	P5	P4	P3	P2	P1	P0	00
D1	PWM7	PWM6	PWM5	PWM4	PWM3	PWM2	PWM1	PWM0	00
D2 ^[1]	-	-	-	-	-	ADCIN2	ADCIN1	ADCIN0	00

[1] The UJA1023 expects to receive data byte D2 only if bit RxDL = 1 (bit 3 of byte D3 in the first I/O configuration data block, see Table 15 and Table 16).

Table 26. PxReq frame bit description

Byte	Bit	Symbol	Description
D0	7 to 0	P[7:0]	Px output value. The Px output value is ignored if Px is configured in cyclic sense or PWM mode.
D1	7 to 0	PWM[7:0]	PWM value.
D2 ^[1]	7 to 3	-	Not used.
	2 to 0	ADCIN[2:0]	ADC analog source channel selection. For example, 000 selects input 0, 001 selects input 1 and 111 selects input 7. The ADC input source is observed only if the INH output is in ADC mode.

[1] The UJA1023 expects to receive data byte D2 only if bit RxDL = 1 (bit 3 of byte D3 in the first I/O configuration data block, see Table 15 and Table 16).

Table 27. PxResp frame bit allocation

Data byte	7	6	5	4	3	2	1	0
D0	P7	P6	P5	P4	P3	P2	P1	P0
D1	EC7	EC6	EC5	EC4	EC3	EC2	EC1	EC0
	SM53	SM52	SM51	SM50	SM43	SM42	SM41	SM40
D2	PxL7	PxL6	PxL5	PxL4	PxL3	PxL2	PxL1	PxL0
	SM73	SM72	SM71	SM70	SM63	SM62	SM61	SM60
D3	PWM7	PWM6	PWM5	PWM4	PWM3	PWM2	PWM1	PWM0
	ADC7	ADC6	ADC5	ADC4	ADC3	ADC2	ADC1	ADC0

Table 28. PxResp frame bit allocation

Byte	Bit	Symbol	Description
D0	7 to 0	P[7:0]	Px input value.
Bytes D1 and D2 if switch matrix is not configured (default)^[1]			
D1	7 to 0	EC[7:0]	Edge capture value.
D2	7 to 0	PxL[7:0]	PxOut latch value.
Bytes D1 and D2 if switch matrix is configured^[1]			
D1	7 to 0	SMxx	Switch matrix value 0. Refer to Figure 8 .
D2	7 to 0	SMxx	Switch matrix value 1.
Byte D3^[1]			
D3	7 to 0	PWM[7:0]	PWM value.
	7 to 0	ADC[7:0]	ADC value. The ADC value is transmitted only if the INH output is in ADC mode (IM0 = 1, IM1 = 0).

[1] Data bytes D2 and D3 are transmitted only if bit TxDL = 1 (bit 4 of byte D3 in the second I/O configuration data block, see [Table 17](#) and [Table 18](#)).

7.3 I/O block

7.3.1 I/O pins P0 to P7

The I/O-pin structure of the UJA1023 is shown in [Figure 10](#).

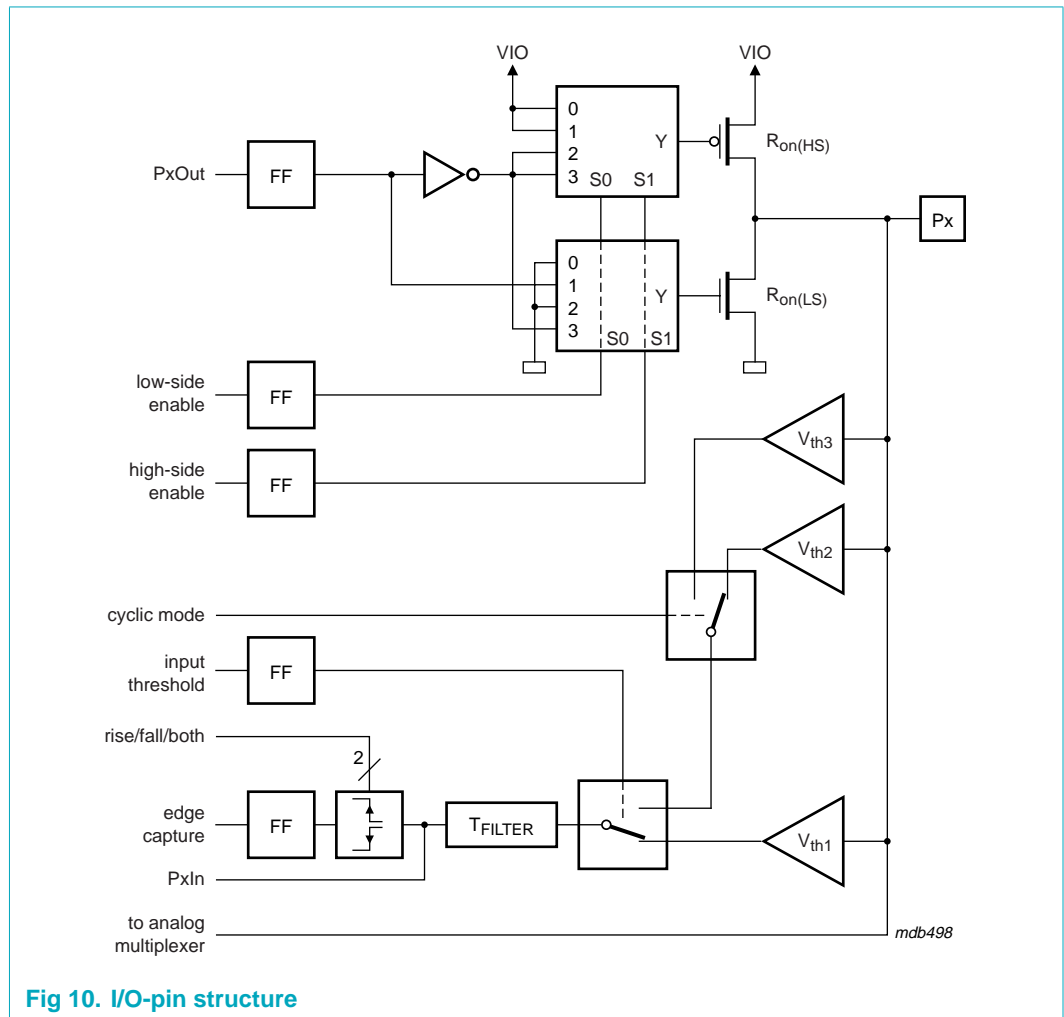

Fig 10. I/O-pin structure

The output is configurable as:

- Push-pull
- High-side switch
- Low-side switch
- High-impedance

The input can be configured:

- To capture on falling, rising or both edges
- To provide an internal pull-up
- With respect to the required threshold V_{th1} , V_{th2} or V_{th3}
- As analog multiplexer for the ADC

Table 29. I/O pin operation [1][2]

Operation	High-side enable	Low-side enable	PxOut	Input threshold	Edge capture
Power-on condition (high-impedance)	0	0	0	0	none
High-impedance	0	0	X	X	X
Low-side open-state	0	1	0	X	X
Low-side close-state	0	1	1	X	X
High-side open-state (Cyclic sense mode: off-state)	1	0	0	X	X
High-side close-state (Cyclic sense mode: on-state)	1	0	1	X ^[3]	X
Push-pull HIGH-state	1	1	1	X	X
Push-pull LOW-state	1	1	0	X	X
Input with pull-up	1	0	1	X	X
Input at threshold V_{th1} (typically 3 V)	X	X	X	0	X
Input at threshold V_{th2} (typically 1.5 V)	X	X	X	1	X
Capture edge at falling and rising edge	X	X	X	X	both
Capture edge at falling edge	X	X	X	X	fall
Capture edge at rising edge	X	X	X	X	rise

[1] X = don't care.

[2] The R_{on} values of the high-side and the low-side switches can be found in [Section 10](#). The $R_{on(HS)}$ value is chosen to provide enough pull-up current for switches; thus no external pull-up resistor is needed. The $R_{on(LS)}$ of the low-side driver is much smaller than the $R_{on(HS)}$ of the high-side driver, which enables the low side driver to drive LEDs.

[3] Refer to [Table 17](#) where threshold TH3 is defined in Cyclic sense mode in case threshold TH2 is selected. This feature is used for diagnosis purposes to check the presence of a switch with integrated parallel resistor (a useful resistor value is $3000 \Omega \pm 1\%$).

7.3.2 INH pin

The inhibit pin INH can be configured in three operation modes: ADC mode, Switch open mode and External regulator mode (see [Section 7.2.4](#) and [Figure 11](#)). After power-on the INH is in External regulator mode (high-side switch is on).

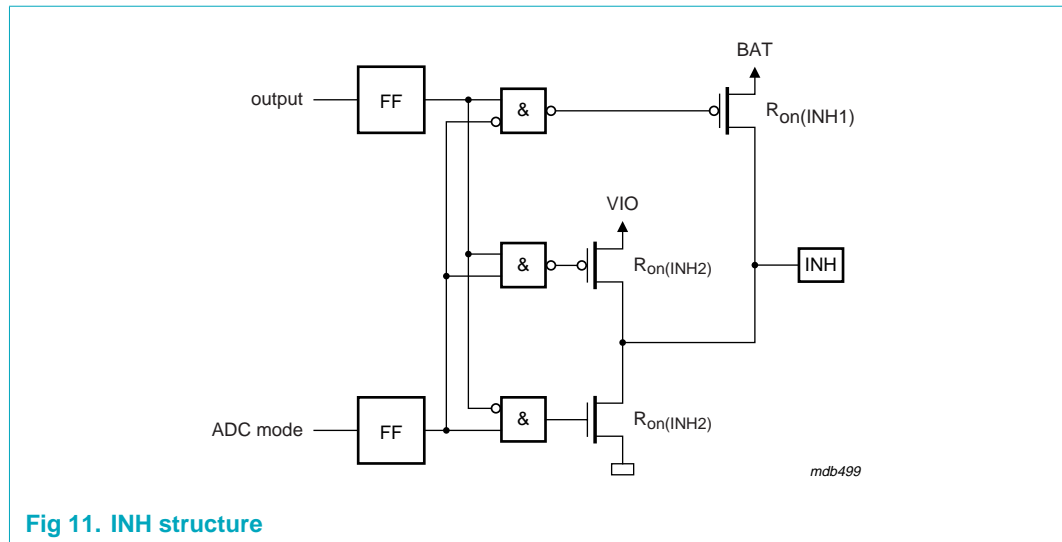

Fig 11. INH structure

7.4 Configuration pins C1 to C3

The structure of the configuration pins C1 to C3 (Cx) is shown in [Figure 12](#). Each pin has a pull-up to the battery. The pull-up is switched on during node address configuration only. In all other cases the Cx have high-impedance behavior.

In order to have a safety margin against ground shift the input threshold of the configuration pins is about $0.5 \times V_{BAT}$.

In addition the configuration pin C3 has a low-side driver to provide the output signal during daisy chain ID configuration.

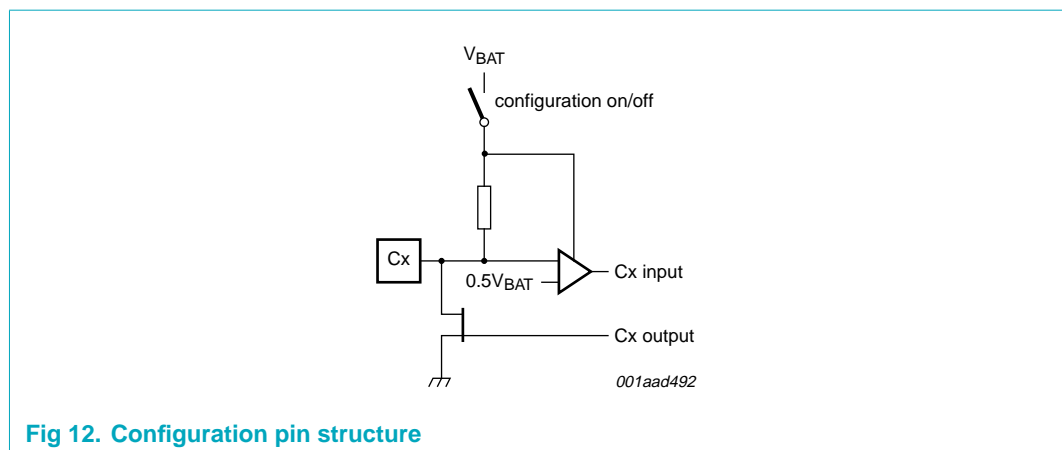

Fig 12. Configuration pin structure

7.5 LIN transceiver

The integrated LIN transceiver of the UJA1023 is compliant with LIN 2.0 / SAE J2602 and provides:

- Integrated 30 k Ω termination resistor
- Internal LIN-termination switch (RTLIN)
- Disabling of termination switch during a short-circuit from LIN to GND

Figure 13 shows the states of the complete LIN transceiver including RTLIN for LIN termination.

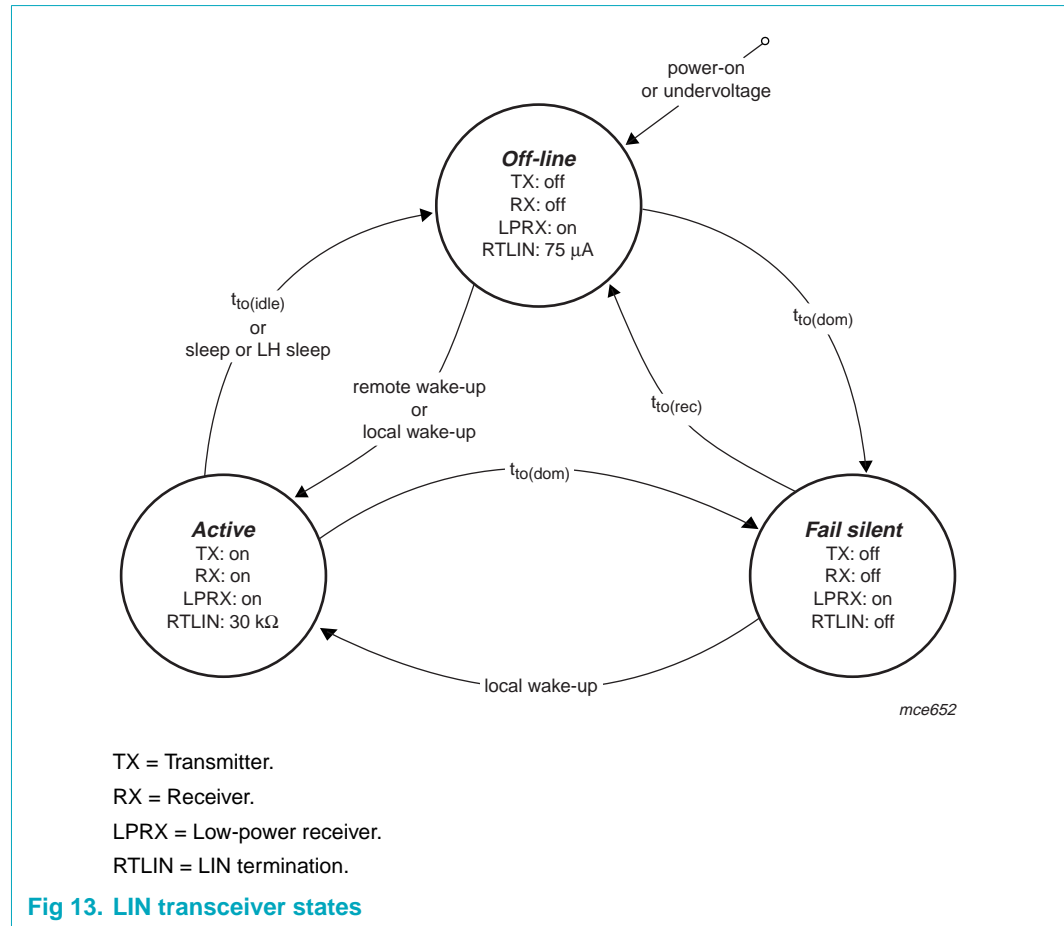

The first mode after power-on is the Off-line mode. The transmitter and receiver are both switched off, but wake-up events will be recognized. Any LIN wake-up event will wake-up the UJA1023.

Within Sleep mode any wake-up event is automatically forwarded to the LIN (protocol) controller, the Normal mode will be entered and the LIN-transceiver automatically enters the Active mode. It should be noted that the first message (wake-up message) will be lost when no wake-up signal has been received before.

The differences between Active, Off-line and Fail silent mode are:

- In Off-line and Fail silent mode the transmitter is off, whereas in Active mode the transmitter is enabled
- During active state with no short-circuit between LIN and GND the internal termination switch RTLIN provides an internal 30 k Ω pull-up resistor to V_{BAT} . In case the LIN wire is shorted to GND for longer than $t_{to(dom)}$, the RTLIN switch switches off in order to make sure that no current is discharging the battery unintentionally and Fail silent mode will be entered
- After failure recovery (in fail silent) when the LIN bus is recessive again the Off-line mode is entered and activates a weak termination of 75 μ A

- Entering Active mode out of Off-line mode results always in switching on the internal 30 k Ω pull-up resistor to battery

7.6 On-chip oscillator

The on-chip oscillator is the time reference for all timers in the LIN controller, auto bit rate detector, ADC and LIN transceiver.

A too-low frequency of the on-chip oscillator or a not-running on-chip oscillator results immediately in Limp home operating mode.

8. Limiting values

Table 30. Limiting values

In accordance with the Absolute Maximum Rating System (IEC 60134). All voltages are referenced to GND.

Symbol	Parameter	Conditions	Min	Max	Unit
V _{BAT}	supply voltage on pin BAT		-0.3	+40	V
V _{VIO}	supply voltage on pin VIO		-0.3	V _{BAT} + 0.3	V
V _{LIN}	voltage on pin LIN	DC value	-27	+40	V
V _{INH}	voltage on pin INH	DC value	-0.3	V _{BAT} + 0.3	V
V _{Cx}	voltage on pins C1 to C3	DC value	-27	+40	V
V _{Px}	voltage on pins P0 to P7	DC value	-0.3	V _{VIO} + 0.3	V
I _{Px}	current on pins P0 to P7	DC value; V _{Px} > V _{VIO} + 0.3 V; V _{Px} < -0.3 V	-15	+15	mA
V _{trt(LIN)}	transient voltages on pin LIN	ISO 7637	-150	+100	V
T _{vj}	virtual junction temperature	[1]	-40	+150	°C
T _{stg}	storage temperature		-55	+150	°C
V _{esd}	electrostatic discharge voltage				
	pins BAT, LIN, C1, C2 and C3	human body model; C = 100 pF; R = 1.5 k Ω	-8	+8	kV
	corner pins	charged device model	-750	+750	V
	other pins	human body model; C = 100 pF; R = 1.5 k Ω	-2	+2	kV
		charged device model	-500	+500	V

[1] Junction temperature in accordance with IEC60747-1. An alternative definition of $T_{vj} = T_{amb} + P \times R_{th(j-a)}$, where $R_{th(j-a)}$ is a fixed value to be used for calculating T_{vj} . The rating for T_{vj} limits the allowable combinations of power dissipation (P) and ambient temperature (T_{amb}).

9. Thermal characteristics

Table 31. Thermal characteristics

Symbol	Parameter	Conditions	Typ	Unit
R _{th(j-a)}	thermal resistance from junction to ambient	in free air	106	K/W

10. Static characteristics

Table 32. Static characteristics

$V_{BAT} = 6.5\text{ V to }27\text{ V}$; $V_{VIO} = 3\text{ V to }27\text{ V}$; $T_{vj} = -40\text{ °C to }+150\text{ °C}$; $R_{L(LIN-BAT)} = 500\ \Omega$; all voltages are referenced to GND; positive current flows into the IC; unless otherwise specified.^[1]

Symbol	Parameter	Conditions	Min	Typ	Max	Unit
Supply: pin BAT						
V_{BAT}	supply voltage on pin BAT	all operating modes	6.5	-	27	V
I_{BAT}	supply current on pin BAT	LH sleep, Sleep and Limp home mode				
		$V_{BAT} = 6.5\text{ V to }8.1\text{ V}$	[2] -	75	100	μA
		$V_{BAT} = 8.1\text{ V to }27\text{ V}$	[2] -	45	65	μA
		Normal mode; LIN receiving recessive				
		$V_{BAT} = 12\text{ V}$	[3] -	0.7	1.4	mA
		$V_{BAT} = 27\text{ V}$	[3] -	1.0	2.0	mA
		Normal mode; LIN receiving dominant				
		$V_{BAT} = 12\text{ V}$	[3] -	1.1	2.2	mA
		$V_{BAT} = 27\text{ V}$	[3] -	1.7	3.4	mA
		Normal mode; LIN sending dominant				
		$V_{BAT} = 12\text{ V}$	[3] -	2.2	4.4	mA
		$V_{BAT} = 27\text{ V}$	[3] -	3.6	7.5	mA
		Additional current if all high- and low-side switches are activated	-	1040	1280	μA
$V_{BAT(pf)}$	V_{BAT} power fail detection voltage		[4] 4.45	-	5.0	V
I/O reference (Px operating range): pin VIO						
V_{VIO}	supply voltage on pin VIO		3	-	$V_{BAT} + 0.3$	V
I_{VIO}	supply current on pin VIO	LH sleep, Sleep and Limp home mode; no load at Px				
		high-side switches disabled	[5] -	1.6	5.0	μA
		high-side switches enabled and active	[5] -	230	280	μA
		Normal mode; ADC enabled; no load at Px and INH; high-side switches enabled	[5] -	520	1000	μA
Configuration: pins C1, C2 and C3						
V_{IH}	HIGH-level input voltage		$0.6 \times V_{BAT}$	-	$V_{BAT} + 0.3$	V
V_{IL}	LOW-level input voltage		-0.3	-	$0.4 \times V_{BAT}$	V
$ I_L $	leakage current	configuration pins disabled	-	-	5	μA
R_{pu}	internal pull-up resistor	configuration pins enabled	5	11	25	k Ω

Table 32. Static characteristics ...continued

$V_{BAT} = 6.5 \text{ V to } 27 \text{ V}$; $V_{VIO} = 3 \text{ V to } 27 \text{ V}$; $T_{vj} = -40^\circ\text{C to } +150^\circ\text{C}$; $R_{L(LIN-BAT)} = 500 \Omega$; all voltages are referenced to GND; positive current flows into the IC; unless otherwise specified.^[1]

Symbol	Parameter	Conditions	Min	Typ	Max	Unit
$V_{OL(C3)}$	LOW-level output voltage on pin C3	external $R_{pu} = 5 \text{ k}\Omega$ to pin BAT; C3 enabled	-	-	$0.2 \times V_{BAT}$	V
$I_{sc(C3)}$	short-circuit current on pin C3	$C3 = V_{BAT}$; C3 enabled	-	-	50	mA
I/O: pins P0 to P7						
$V_{IH(th1)}$	HIGH-level input voltage V_{th1}	$V_{VIO} \geq 3.7 \text{ V}$	3.7	-	$V_{VIO} + 0.3$	V
$V_{IL(th1)}$	LOW-level input voltage V_{th1}	$V_{VIO} \geq 3.7 \text{ V}$	-0.3	-	+2.1	V
$V_{IH(th2)}$	HIGH-level input voltage V_{th2}		2.0	-	$V_{VIO} + 0.3$	V
$V_{IL(th2)}$	LOW-level input voltage V_{th2}		-0.3	-	+0.8	V
$V_{IH(th3)}$	HIGH-level input voltage V_{th3}	$V_{VIO} \geq 10 \text{ V}$	$V_{VIO} - 0.8$	-	$V_{VIO} + 0.3$	V
$V_{IL(th3)}$	LOW-level input voltage V_{th3}	$V_{VIO} \geq 10 \text{ V}$	-0.3	-	$V_{VIO} - 2.5$	V
$ I_L $	leakage current	$V_I = V_{VIO}$ or GND	-	-	10	μA
$R_{on(HS)}$	high-side on-state resistance	$V_{Px} = V_{VIO} - 1 \text{ V}$; per switch	550	1200	3000	Ω
$I_{sc(HS)}$	high-side short-circuit current	$V_{Px} = 0 \text{ V}$	^[6] -3.1	-2.0	-0.8	mA
$R_{on(LS)}$	low-side on-state resistance	$V_{Px} = 1 \text{ V}$; per switch	25	50	83	Ω
$I_{sc(LS)}$	low-side short-circuit current	$V_{Px} = V_{VIO}$	^[6] 10	23	40	mA
Special function: pin INH						
$V_{BAT-INH}$	voltage drop	INH mode; $I_{INH} = -1 \text{ mA}$	-	1.2	1.8	V
$ I_L $	leakage current	$V_{INH} = 0 \text{ V}$	-	-	5	μA
Bus line: pin LIN						
$V_{O(dom)}$	LIN dominant output voltage	$7.0 \text{ V} < V_{BAT} < 18 \text{ V}$	0	-	$0.2 \times V_{BAT}$	V
$I_{L(H)}$	HIGH-level leakage current	$7.0 \text{ V} < V_{BAT} < 18 \text{ V}$; $V_{LIN} = V_{BAT}$	-10	-	+10	μA
$I_{L(L)}$	LOW-level leakage current	Fail silent mode; $V_{LIN} = 0 \text{ V}$; $t > t_{to(dom)}$	-10	0	+10	μA
I_{pu}	LIN pull-up current	Off-line mode; $V_{LIN} = 0 \text{ V}$; $t < t_{to(dom)}$	-150	-60	-10	μA
$R_{pu(slave)}$	slave termination pull-up	Active mode	20	30	47	$\text{k}\Omega$
I_L	leakage current	$V_{BAT} = 0 \text{ V}$	^[7] -	0	-	μA
$I_{O(sc)}$	short-circuit output current	LIN dominant; $t < t_{to(dom)}$				
		$V_{LIN} = 12 \text{ V}$; $V_{BAT} = 12 \text{ V}$	27	40	60	mA
		$V_{LIN} = 18 \text{ V}$; $V_{BAT} = 18 \text{ V}$	40	60	86	mA
$V_{th(dom)}$	receiver dominant state voltage	Active mode	-	-	$0.4 \times V_{BAT}$	V
$V_{th(rec)}$	receiver recessive state voltage	Active mode	$0.6 \times V_{BAT}$	-	-	V
$V_{cen(RX)}$	receiver center voltage	Active mode	$0.475 \times V_{BAT}$	$0.5 \times V_{BAT}$	$0.525 \times V_{BAT}$	V
$V_{hys(RX)}$	receiver hysteresis voltage	Active mode	$0.05 \times V_{BAT}$	-	$0.175 \times V_{BAT}$	V

- [1] All parameters are guaranteed over the virtual junction temperature range by design. Products are 100 % tested at 125 °C ambient temperature on wafer level (pre-testing). Cased products are 100 % tested at 25 °C ambient temperature (final testing). Both pre-testing and final testing use correlated test conditions to cover the specified temperature and power supply voltage ranges.
- [2] All outputs turned off, LIN recessive, V_{th1} selected.
- [3] All outputs turned off.
- [4] Configuration is lost when V_{BAT} is below 5 V.
- [5] V_{th1} on, V_{th2} off, V_{th3} off.
- [6] Outputs are not temperature protected.
- [7] Not tested in production.

11. Dynamic characteristics

Table 33. Dynamic characteristics

$V_{BAT} = 6.5 \text{ V to } 27 \text{ V}$; $V_{VIO} = 3 \text{ V to } 27 \text{ V}$; $T_{vj} = -40 \text{ °C to } +150 \text{ °C}$; $R_{L(LIN-BAT)} = 500 \text{ }\Omega$; all voltages are referenced to GND; unless otherwise specified.^[1]

Symbol	Parameter	Conditions	Min	Typ	Max	Unit
I/O processing						
$t_{process}$	PxReq to output	after valid LIN message	[2] -	200	-	μs
$t_{conv(ADC)}$	conversion time ADC		[2][3] -	1.5	-	ms
LIN transceiver; see Figure 14^[4]						
$\delta 1$	duty cycle 1	$V_{th(rec)(max)} = 0.744 \times V_{BAT}$; $V_{th(dom)(max)} = 0.581 \times V_{BAT}$; LSC = 0; $t_{bit} = 50 \text{ }\mu\text{s}$; $V_{BAT} = 7 \text{ V to } 18 \text{ V}$	[5] 0.396	-	-	
$\delta 2$	duty cycle 2	$V_{th(rec)(min)} = 0.422 \times V_{BAT}$; $V_{th(dom)(min)} = 0.284 \times V_{BAT}$; LSC = 0; $t_{bit} = 50 \text{ }\mu\text{s}$; $V_{BAT} = 7.6 \text{ V to } 18 \text{ V}$	[6] -	-	0.581	
$\delta 3$	duty cycle 3	$V_{th(rec)(max)} = 0.778 \times V_{BAT}$; $V_{th(dom)(max)} = 0.616 \times V_{BAT}$; LSC = 1; $t_{bit} = 96 \text{ }\mu\text{s}$; $V_{BAT} = 7 \text{ V to } 18 \text{ V}$	[5] 0.417	-	-	
$\delta 4$	duty cycle 4	$V_{th(rec)(min)} = 0.389 \times V_{BAT}$; $V_{th(dom)(min)} = 0.251 \times V_{BAT}$; LSC = 1; $t_{bit} = 96 \text{ }\mu\text{s}$; $V_{BAT} = 7.6 \text{ V to } 18 \text{ V}$	[6] -	-	0.590	
$t_{PHL(RX)}$, $t_{PLH(RX)}$	propagation delay of receiver		[7] -	-	6	μs
$t_{P(RX)(sym)}$	symmetry of receiver propagation delay rising edge with respect to falling edge		[7] -2	-	+2	μs
LIN protocol controller						
$t_{to(idle)}$	bus idle time-out		[2] 4.1	-	18.0	s
$t_{to(dom)}$	bus dominant time-out		[2] 32	-	270	ms
$t_{to(rec)}$	bus recessive time-out		[2] 15	-	65	μs
$t_{wake(bus)}$	network wake-up signal time	after local wake-up, sent by slave	[2] 0.25	-	5	ms
$t_{wake(local)}$	bus wake-up dominant time	Sleep mode, sent by master	[2] 30	100	150	μs

Table 33. Dynamic characteristics ...continued

$V_{BAT} = 6.5 \text{ V to } 27 \text{ V}$; $V_{VIO} = 3 \text{ V to } 27 \text{ V}$; $T_{vj} = -40 \text{ }^\circ\text{C to } +150 \text{ }^\circ\text{C}$; $R_{L(LIN-BAT)} = 500 \text{ } \Omega$; all voltages are referenced to GND; unless otherwise specified.^[1]

Symbol	Parameter	Conditions	Min	Typ	Max	Unit
Automatic bit rate detection						
$t_{det(syncbrk)}$	sync break detection threshold		[4] -	$10 \times t_{bit}$	-	μs
$f_{tol(sync)}$	total tolerance slave synchronized	complete message	-	-	2	%
Cyclic function; see Figure 7						
T_{cy}	cycle period		[2] -	16	-	ms
$t_{on(PxOut)}$	PxOut pin turned on		[2] -	350	-	μs
$t_{sample(PxIn)}$	PxIn sample time		[2] -	262	-	μs
ADC function						
E_{ADC}	total ADC error	$R = 100 \text{ k}\Omega$; $C = 10 \text{ nF}$				
		$V_{VIO} = 6.5 \text{ V to } 12 \text{ V}$; $V_{BAT} = 6.5 \text{ V to } 12 \text{ V}$	[8] -	-	4	LSB
		$V_{VIO} = 3 \text{ V to } 27 \text{ V}$; $V_{BAT} = 6.5 \text{ V to } 27 \text{ V}$	[8] -	-	6	LSB

[1] All parameters are guaranteed over the virtual junction temperature range by design. Products are 100 % tested at 125 °C ambient temperature on wafer level (pre-testing). Cased products are 100 % tested at 25 °C ambient temperature (final testing). Both pre-testing and final testing use correlated test conditions to cover the specified temperature and power supply voltage ranges.

[2] Guaranteed by design.

[3] Analog-to-digital conversion starts when valid sync break and sync field is received.

[4] t_{bit} = selected bit time 50 μs or 96 μs (20 kbit/s or 10.4 kbit/s), depends on LSC bit; bus load conditions are (C parallel to R): $C_{bus} = 1 \text{ nF}$ and $R_{bus} = 1 \text{ k}\Omega$, $C_{bus} = 6.8 \text{ nF}$ and $R_{bus} = 660 \text{ } \Omega$ or $C_{bus} = 10 \text{ nF}$ and $R_{bus} = 500 \text{ } \Omega$.

$$[5] \quad \delta_1, \delta_3 = \frac{t_{bus(rec)(min)}}{2 \times t_{bit}}$$

$$[6] \quad \delta_2, \delta_4 = \frac{t_{bus(rec)(max)}}{2 \times t_{bit}}$$

[7] RXD is an internal signal.

[8] Not tested.

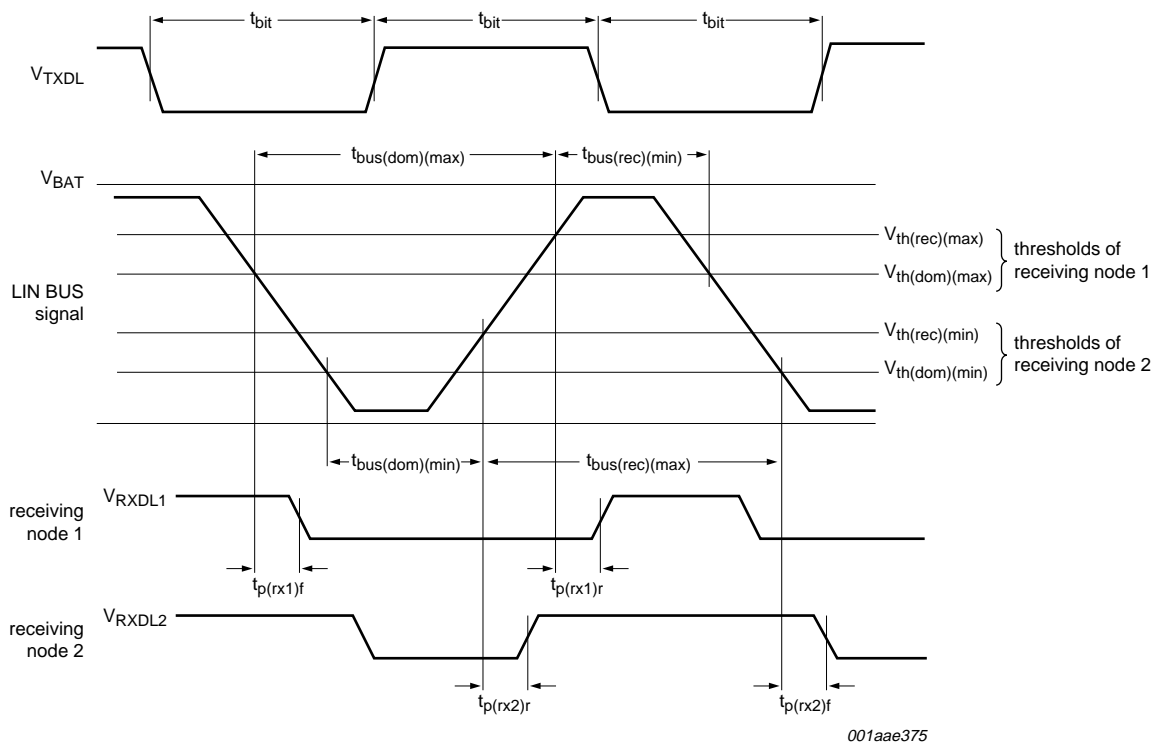

Fig 14. Timing diagram LIN transceiver

12. Application information

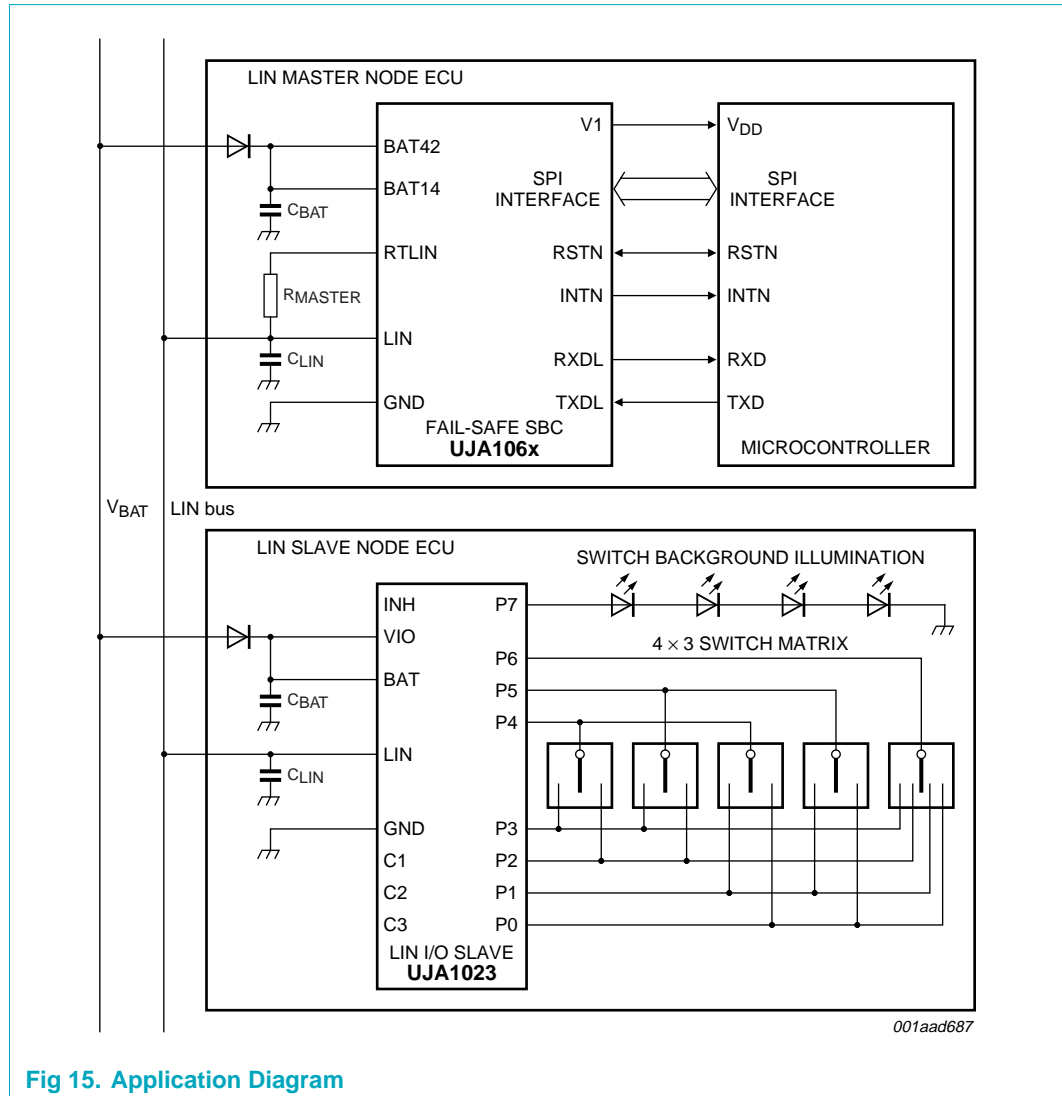

Fig 15. Application Diagram

13. Test information

Immunity against automotive transients (malfunction and damage) in accordance with LIN EMC Test Specification / Version 1.0; August 1, 2004.

13.1 Quality information

This product has been qualified to the appropriate Automotive Electronics Council (AEC) standard Q100 or Q101 and is suitable for use in automotive critical applications.

14. Package outline

SO16: plastic small outline package; 16 leads; body width 3.9 mm

SOT109-1

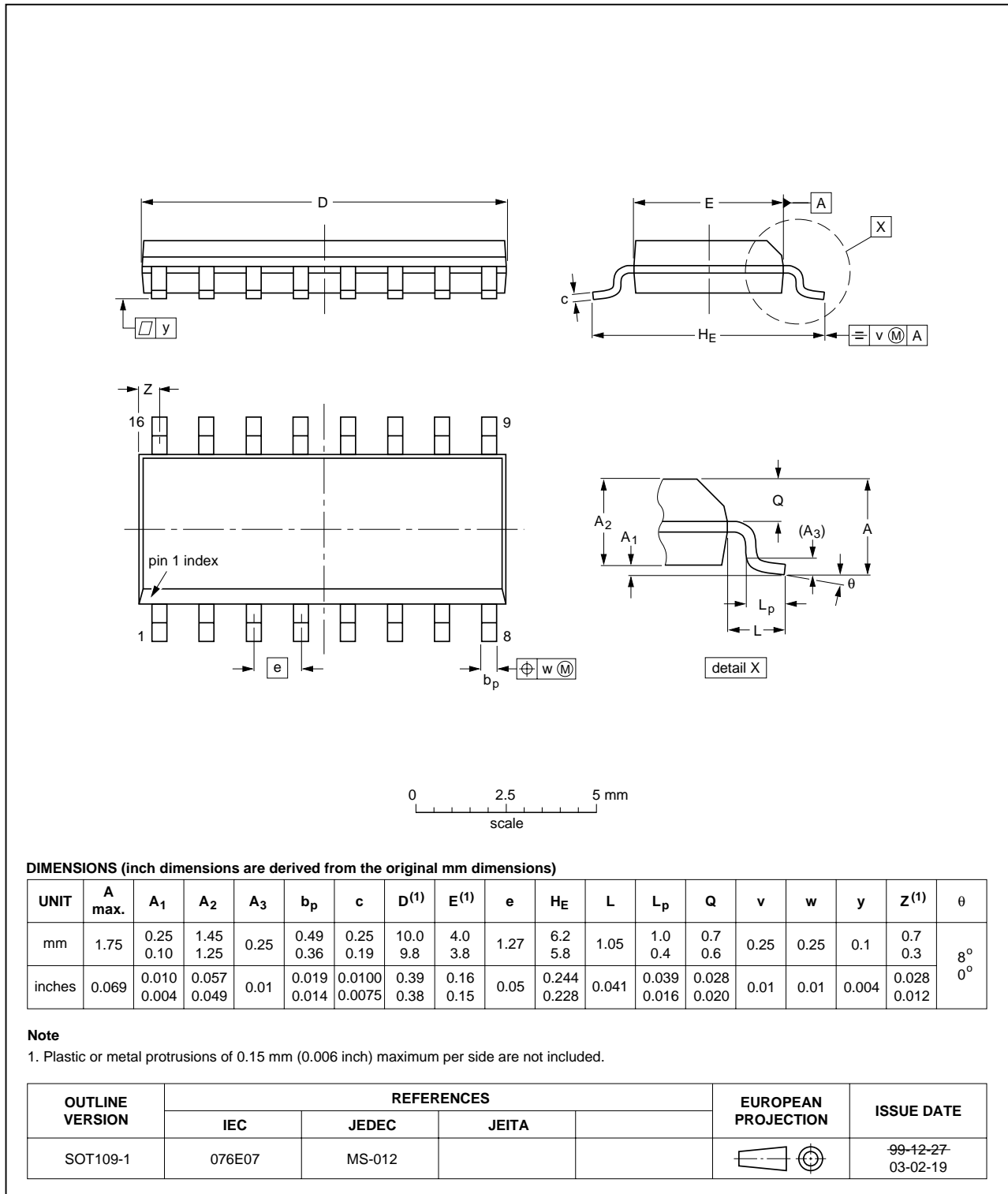

Fig 16. Package outline SOT109-1 (SO16)

15. Soldering

15.1 Introduction to soldering surface mount packages

There is no soldering method that is ideal for all surface mount IC packages. Wave soldering can still be used for certain surface mount ICs, but it is not suitable for fine pitch SMDs. In these situations reflow soldering is recommended.

15.2 Reflow soldering

Reflow soldering requires solder paste (a suspension of fine solder particles, flux and binding agent) to be applied to the printed-circuit board by screen printing, stencilling or pressure-syringe dispensing before package placement. Driven by legislation and environmental forces the worldwide use of lead-free solder pastes is increasing.

Several methods exist for reflowing; for example, convection or convection/infrared heating in a conveyor type oven. Throughput times (preheating, soldering and cooling) vary between 100 seconds and 200 seconds depending on heating method.

Typical reflow temperatures range from 215 °C to 260 °C depending on solder paste material. The peak top-surface temperature of the packages should be kept below:

Table 34. SnPb eutectic process - package peak reflow temperatures (from J-STD-020C July 2004)

Package thickness	Volume mm ³ < 350	Volume mm ³ ≥ 350
< 2.5 mm	240 °C + 0/-5 °C	225 °C + 0/-5 °C
≥ 2.5 mm	225 °C + 0/-5 °C	225 °C + 0/-5 °C

Table 35. Pb-free process - package peak reflow temperatures (from J-STD-020C July 2004)

Package thickness	Volume mm ³ < 350	Volume mm ³ 350 to 2000	Volume mm ³ > 2000
< 1.6 mm	260 °C + 0 °C	260 °C + 0 °C	260 °C + 0 °C
1.6 mm to 2.5 mm	260 °C + 0 °C	250 °C + 0 °C	245 °C + 0 °C
≥ 2.5 mm	250 °C + 0 °C	245 °C + 0 °C	245 °C + 0 °C

Moisture sensitivity precautions, as indicated on packing, must be respected at all times.

15.3 Wave soldering

Conventional single wave soldering is not recommended for surface mount devices (SMDs) or printed-circuit boards with a high component density, as solder bridging and non-wetting can present major problems.

To overcome these problems the double-wave soldering method was specifically developed.

If wave soldering is used the following conditions must be observed for optimal results:

- Use a double-wave soldering method comprising a turbulent wave with high upward pressure followed by a smooth laminar wave.
- For packages with leads on two sides and a pitch (e):

- larger than or equal to 1.27 mm, the footprint longitudinal axis is **preferred** to be parallel to the transport direction of the printed-circuit board;
- smaller than 1.27 mm, the footprint longitudinal axis **must** be parallel to the transport direction of the printed-circuit board.

The footprint must incorporate solder thieves at the downstream end.

- For packages with leads on four sides, the footprint must be placed at a 45° angle to the transport direction of the printed-circuit board. The footprint must incorporate solder thieves downstream and at the side corners.

During placement and before soldering, the package must be fixed with a droplet of adhesive. The adhesive can be applied by screen printing, pin transfer or syringe dispensing. The package can be soldered after the adhesive is cured.

Typical dwell time of the leads in the wave ranges from 3 seconds to 4 seconds at 250 °C or 265 °C, depending on solder material applied, SnPb or Pb-free respectively.

A mildly-activated flux will eliminate the need for removal of corrosive residues in most applications.

15.4 Manual soldering

Fix the component by first soldering two diagonally-opposite end leads. Use a low voltage (24 V or less) soldering iron applied to the flat part of the lead. Contact time must be limited to 10 seconds at up to 300 °C.

When using a dedicated tool, all other leads can be soldered in one operation within 2 seconds to 5 seconds between 270 °C and 320 °C.

15.5 Package related soldering information

Table 36. Suitability of surface mount IC packages for wave and reflow soldering methods

Package ^[1]	Soldering method	
	Wave	Reflow ^[2]
BGA, HTSSON..T ^[3] , LBGA, LFBGA, SQFP, SSOP..T ^[3] , TFBGA, VFBGA, XSON	not suitable	suitable
DHVQFN, HBCC, HBGA, HLQFP, HSO, HSOP, HSQFP, HSSON, HTQFP, HTSSOP, HVQFN, HVSON, SMS	not suitable ^[4]	suitable
PLCC ^[5] , SO, SOJ	suitable	suitable
LQFP, QFP, TQFP	not recommended ^{[5][6]}	suitable
SSOP, TSSOP, VSO, VSSOP	not recommended ^[7]	suitable
CWQCCN..L ^[8] , PMFP ^[9] , WQCCN..L ^[8]	not suitable	not suitable

[1] For more detailed information on the BGA packages refer to the *(LF)BGA Application Note* (AN01026); order a copy from your Philips Semiconductors sales office.

[2] All surface mount (SMD) packages are moisture sensitive. Depending upon the moisture content, the maximum temperature (with respect to time) and body size of the package, there is a risk that internal or external package cracks may occur due to vaporization of the moisture in them (the so called popcorn effect). For details, refer to the Drypack information in the *Data Handbook IC26; Integrated Circuit Packages; Section: Packing Methods*.

- [3] These transparent plastic packages are extremely sensitive to reflow soldering conditions and must on no account be processed through more than one soldering cycle or subjected to infrared reflow soldering with peak temperature exceeding $217\text{ °C} \pm 10\text{ °C}$ measured in the atmosphere of the reflow oven. The package body peak temperature must be kept as low as possible.
- [4] These packages are not suitable for wave soldering. On versions with the heatsink on the bottom side, the solder cannot penetrate between the printed-circuit board and the heatsink. On versions with the heatsink on the top side, the solder might be deposited on the heatsink surface.
- [5] If wave soldering is considered, then the package must be placed at a 45° angle to the solder wave direction. The package footprint must incorporate solder thieves downstream and at the side corners.
- [6] Wave soldering is suitable for LQFP, QFP and TQFP packages with a pitch (e) larger than 0.8 mm; it is definitely not suitable for packages with a pitch (e) equal to or smaller than 0.65 mm.
- [7] Wave soldering is suitable for SSOP, TSSOP, VSO and VSSOP packages with a pitch (e) equal to or larger than 0.65 mm; it is definitely not suitable for packages with a pitch (e) equal to or smaller than 0.5 mm.
- [8] Image sensor packages in principle should not be soldered. They are mounted in sockets or delivered pre-mounted on flex foil. However, the image sensor package can be mounted by the client on a flex foil by using a hot bar soldering process. The appropriate soldering profile can be provided on request.
- [9] Hot bar soldering or manual soldering is suitable for PMFP packages.

16. Revision history

Table 37. Revision history

Document ID	Release date	Data sheet status	Change notice	Supersedes
UJA1023_4	20060705	Product data sheet	-	UJA1023_3
Modifications:		<ul style="list-style-type: none"> • Section 7.2.3.4 "Cyclic sense mode": updated • Table 25 "PxReq frame bit allocation": updated • Table 26 "PxReq frame bit description": updated • Table 32 "Static characteristics": updated • Table 33 "Dynamic characteristics": updated • Previous Fig 16 "Test circuit for automotive transients" is replaced by text 		
UJA1023_3	20060209	Preliminary data sheet	-	UJA1023_2
UJA1023_2 (9397 750 12022)	20050203	Objective specification	-	-

17. Legal information

17.1 Data sheet status

Document status ^{[1][2]}	Product status ^[3]	Definition
Objective [short] data sheet	Development	This document contains data from the objective specification for product development.
Preliminary [short] data sheet	Qualification	This document contains data from the preliminary specification.
Product [short] data sheet	Production	This document contains the product specification.

[1] Please consult the most recently issued document before initiating or completing a design.

[2] The term 'short data sheet' is explained in section "Definitions".

[3] The product status of device(s) described in this document may have changed since this document was published and may differ in case of multiple devices. The latest product status information is available on the Internet at URL <http://www.semiconductors.philips.com>.

17.2 Definitions

Draft — The document is a draft version only. The content is still under internal review and subject to formal approval, which may result in modifications or additions. Philips Semiconductors does not give any representations or warranties as to the accuracy or completeness of information included herein and shall have no liability for the consequences of use of such information.

Short data sheet — A short data sheet is an extract from a full data sheet with the same product type number(s) and title. A short data sheet is intended for quick reference only and should not be relied upon to contain detailed and full information. For detailed and full information see the relevant full data sheet, which is available on request via the local Philips Semiconductors sales office. In case of any inconsistency or conflict with the short data sheet, the full data sheet shall prevail.

17.3 Disclaimers

General — Information in this document is believed to be accurate and reliable. However, Philips Semiconductors does not give any representations or warranties, expressed or implied, as to the accuracy or completeness of such information and shall have no liability for the consequences of use of such information.

Right to make changes — Philips Semiconductors reserves the right to make changes to information published in this document, including without limitation specifications and product descriptions, at any time and without notice. This document supersedes and replaces all information supplied prior to the publication hereof.

Suitability for use — Philips Semiconductors products are not designed, authorized or warranted to be suitable for use in medical, military, aircraft, space or life support equipment, nor in applications where failure or

malfunction of a Philips Semiconductors product can reasonably be expected to result in personal injury, death or severe property or environmental damage. Philips Semiconductors accepts no liability for inclusion and/or use of Philips Semiconductors products in such equipment or applications and therefore such inclusion and/or use is at the customer's own risk.

Applications — Applications that are described herein for any of these products are for illustrative purposes only. Philips Semiconductors makes no representation or warranty that such applications will be suitable for the specified use without further testing or modification.

Limiting values — Stress above one or more limiting values (as defined in the Absolute Maximum Ratings System of IEC 60134) may cause permanent damage to the device. Limiting values are stress ratings only and operation of the device at these or any other conditions above those given in the Characteristics sections of this document is not implied. Exposure to limiting values for extended periods may affect device reliability.

Terms and conditions of sale — Philips Semiconductors products are sold subject to the general terms and conditions of commercial sale, as published at <http://www.semiconductors.philips.com/profile/terms>, including those pertaining to warranty, intellectual property rights infringement and limitation of liability, unless explicitly otherwise agreed to in writing by Philips Semiconductors. In case of any inconsistency or conflict between information in this document and such terms and conditions, the latter will prevail.

No offer to sell or license — Nothing in this document may be interpreted or construed as an offer to sell products that is open for acceptance or the grant, conveyance or implication of any license under any copyrights, patents or other industrial or intellectual property rights.

17.4 Trademarks

Notice: All referenced brands, product names, service names and trademarks are the property of their respective owners.

18. Contact information

For additional information, please visit: <http://www.semiconductors.philips.com>

For sales office addresses, send an email to: sales.addresses@www.semiconductors.philips.com

19. Contents

1	General description	1	8	Limiting values	36
2	Features	2	9	Thermal characteristics	36
3	Quick reference data	2	10	Static characteristics	37
4	Ordering information	2	11	Dynamic characteristics	39
5	Block diagram	3	12	Application information	42
6	Pinning information	3	13	Test information	42
6.1	Pinning	3	13.1	Quality information	42
6.2	Pin description	4	14	Package outline	43
7	Functional description	4	15	Soldering	44
7.1	Short description of the UJA1023	4	15.1	Introduction to soldering surface mount packages	44
7.1.1	LIN controller	4	15.2	Reflow soldering	44
7.1.2	LIN transceiver (including termination)	4	15.3	Wave soldering	44
7.1.3	Automatic bit rate detection	5	15.4	Manual soldering	45
7.1.4	Oscillator	5	15.5	Package related soldering information	45
7.1.5	I/O block	5	16	Revision history	46
7.1.6	ADC	5	17	Legal information	47
7.1.7	PWM	5	17.1	Data sheet status	47
7.1.8	Cyclic sense	5	17.2	Definitions	47
7.2	LIN controller	5	17.3	Disclaimers	47
7.2.1	Configuration	5	17.4	Trademarks	47
7.2.1.1	Message sequence	5	18	Contact information	47
7.2.1.2	LIN slave node address assignment	8	19	Contents	48
7.2.1.3	Assign frame ID	14			
7.2.1.4	Read by identifier	15			
7.2.1.5	I/O configuration	16			
7.2.1.6	Configuration examples	22			
7.2.2	Operating modes	24			
7.2.2.1	Configuration mode	25			
7.2.2.2	Normal mode	25			
7.2.2.3	Sleep mode	25			
7.2.2.4	Limp home sleep mode	25			
7.2.2.5	Limp home mode and Standby mode	26			
7.2.3	I/O pin modes	26			
7.2.3.1	Input	26			
7.2.3.2	Level mode	26			
7.2.3.3	PWM mode	26			
7.2.3.4	Cyclic sense mode	26			
7.2.3.5	Switch matrix mode	27			
7.2.3.6	ADC mode	28			
7.2.4	INH pin mode	29			
7.2.5	LIN-I/O message frames	29			
7.3	I/O block	32			
7.3.1	I/O pins P0 to P7	32			
7.3.2	INH pin	33			
7.4	Configuration pins C1 to C3	34			
7.5	LIN transceiver	34			
7.6	On-chip oscillator	36			

Please be aware that important notices concerning this document and the product(s) described herein, have been included in section 'Legal information'.



© Koninklijke Philips Electronics N.V. 2006. All rights reserved.

For more information, please visit: <http://www.semiconductors.philips.com>.

For sales office addresses, email to: sales.addresses@www.semiconductors.philips.com.

Date of release: 5 July 2006

Document identifier: UJA1023_4